

NIAS DUAL



GB

Line
tech

High quality
Italian product



INSTALLATION
USE AND MAINTENANCE



Dear Customer,

Thank you for choosing and buying one of our boilers. Please read these instructions carefully in order to install, operate and service the boiler properly.

The Manufacturer recommends that Customers contact authorized qualified personnel only for maintenance and repair operations.

General information for fitters, maintenance technicians and users

This INSTRUCTION MANUAL, which is an integral and indispensable part of the product, must be handed over to the user by the fitter and must be kept in a safe place for future reference. The manual must accompany the boiler should it be sold or its possession transferred.



This boiler is designed for connection to a central heating system and to a hot domestic water system.

Any other use is considered incorrect and therefore dangerous.

The boiler must be installed in compliance with the applicable laws and standards and according to the manufacturer's instructions given in this manual. Incorrect installation may cause injury to people or animals and damage to property. The manufacturer shall not be held liable for any such injury or damage.

Damage or injury caused by incorrect installation or use, or by failure to follow the manufacturer's instructions will relieve manufacturer of any and all contractual and extra-contractual liability.

Before installing the boiler, check that the technical data correspond to the requirements for its correct use in the system.

Check that the boiler is intact and has not been damaged during transport and handling. Do not install equipment which is damaged or faulty.

Do not obstruct the air intake or heat dissipation openings.

Only Manufacturer-approved accessories or optional kits must be installed.

All the packaging materials can be recycled and must be disposed of correctly. They must be sent to a specific waste management site. Keep the packaging out of the reach of children as it may represent a hazard.

In the event of failure or faulty operation, switch off the boiler. Do not attempt to make any repairs and contact a qualified technician.

Manufacturer-approved parts must be used for all repairs to the boiler.

Failures to comply with the above requirements may affect the safety of the boiler and endanger people, animals and property.



Routine boiler maintenance should be performed according to the schedule in the relevant section of this manual.

Appropriate boiler maintenance ensures efficient operation, preservation of the environment, and safety for people, animals and property. Incorrect and irregular maintenance can be a source of danger for people, animals and property.

The Manufacturer recommends that Customers contact an authorized Service Centre for maintenance and repairs.

If the boiler is to remain inactive for a long time, disconnect it from the power mains and close the gas tap.

Warning! If the boiler is disconnected from the mains, the electronic anti-freeze function will not operate.

Should there be a risk of freezing, add anti-freeze to the heating system. It is not advisable to empty the system as this may result in damage. Use specific anti-freeze products suitable for multi-metal heating systems.



If you smell gas:

- do not touch any electrical switches and do not turn on electrical appliances;
 - do not ignite flames and extinguish any cigarettes;
 - close the main gas tap;
 - open doors and windows;
 - contact a Service Centre, a qualified fitter or the gas supply company.
- Never use a flame to detect a gas leak.**



WARNING

This boiler has been built for installation in the country indicated on packaging and the rating plate.

Installation in a country other than the specified one may be a source of danger for people, animals and property.

The Manufacturer cannot be held contractually or extra-contractually liable in the event of failure to comply with the above.

RAPID OPERATING INSTRUCTIONS

The following instructions will help you to switch the boiler on quickly and regulate it for immediate use.



It is presumed that the boiler has been installed by a qualified fitter, it has been used before and is ready to operate correctly.



If any accessories have been fitted on the boiler, these instructions will not cover them. You will therefore have to refer to the full boiler instructions as well as to the specific instructions for the accessories.

This manual contains full details of how the boiler works, and full operating and safety instructions.

1. Open the gas cock.
2. Turn the master switch to **ON**: the display comes on and shows the function set via the boiler selector (**2**, fig. 1).
3. If you **do not wish** to activate the heating function, turn the boiler selector (**2**, fig. 1) to SUMMER. This will activate domestic hot water (DHW) only, and the display will show the flow water temperature.



Boiler selector on SUMMER

4. If **you wish** to activate the heating function, turn the boiler selector (**2**, fig. 1) to WINTER. This will activate both DHW and heating, and the display will show the flow water temperature.



Boiler selector on WINTER

5. If you wish to activate the Aqua Premium system, proceed as follows to regulate the hot water temperature. Turn the regulator (**3**, fig. 1) anticlockwise as far as it will go. The storage symbol , is displayed, showing that the Aqua Premium system is active (if it was already active, this operation deactivates it). Then turn the selector (**3**) until the desired hot water temperature is displayed (at least 40°C). While the DHW temperature is being regulated, the display shows the temperature setting and the tap symbol flashes.



DHW temperature regulator



Liquid crystal display (LCD)

6. To regulate the CH water temperature, first set the regulator (**4**, fig. 1) to 3 o'clock (about 70°C), then regulate it as required. While the DHW temperature is being regulated, the LCD displays the temperature setting and the tap symbol flashes.



CH water temperature regulator



Liquid crystal display (LCD)

7. Set the desired temperature on the (optional) room thermostat in the building.

The boiler is now ready to operate.

If the boiler shuts down, turn the boiler selector (**2** in fig. 1) to reset for a few seconds, then back to the desired position. If the boiler does not restart, contact an Authorised Service Centre.



Boiler selector on RESET

TABLE OF CONTENTS

General information for the fitters, maintenance technicians and users	page 3
Rapid operating instructions	page 4
1. User instructions	page 7
1.1. Control Panel	page 7
1.2. LCD	page 8
1.3. BOILER STATUS – LCD ACTIVATION CORRESPONDENCE	page 9
1.3.1. Normal operation	page 9
1.3.2. Malfunction	page 9
1.4. Operating the boiler	page 10
1.4.1. Switching on	page 10
1.4.2. CH function	page 10
1.4.3. DHW function	page 10
1.4.3.1. AQUA PREMIUM system	page 10
1.4.3.2. Instantaneous production of DHW	page 11
1.4.4. Anti-freeze function	page 11
1.4.5. Pump and valve anti-shutdown function	page 12
1.4.6. Operation with (optional) remote control	page 12
1.4.7. Operation with an (optional) external probe	page 12
1.5. Boiler shutdown	page 13
1.5.1. Burner shutdown	page 13
1.5.2. Shutdown due to overheating	page 13
1.5.3. Shutdown due to air/flue gas system malfunction	page 13
1.5.4. Shutdown due to insufficient water pressure	page 13
1.5.5. Alarm due to temperature probe malfunction	page 14
1.5.6. Alarm due to external probe malfunction (optional)	page 14
1.5.7. Alarm due to gas valve modulator malfunction	page 14
1.5.8. Alarm due to (optional) remote control connection malfunction	page 14
1.6. Maintenance	page 14
1.7. Notes for the user	page 14
2. Technical features and dimensions	page 15
2.1. Technical features	page 15
2.2. Dimensions	page 16
2.3. Boiler layout	page 18
2.4. Operating data	page 19
2.5. Technical specifications	page 20
3. Instructions for the fitter	page 21
3.1. Installation standards	page 21
3.2. Installation	page 21
3.2.1. Packaging	page 21
3.2.2. Deciding where to install the boiler	page 21
3.2.3. Positioning the boiler	page 21
3.2.4. Installing the boiler	page 23
3.2.5. Boiler room ventilation	page 23
3.2.6. Air/flue gas system for natural draught boilers (BTN)	page 23
3.2.7. Air/flue gas system for forced draught boilers (BTFS)	page 24
3.2.7.1. Air/flue gas pipe configuration: B22, C12, C32, C42, C52, C82	page 25
3.2.7.2. Air/flue gas system with 100/60 mm diameter coaxial pipes	page 26
3.2.7.3. Air/flue gas system with 80 mm diameter split pipes	page 27
3.2.7.4. Direct air intake and flue gas discharge with 80 mm diameter duct	page 28
3.2.8. Measuring combustion efficiency	page 29
3.2.8.1. Chimney-sweep function	page 29
3.2.8.2. Measurement procedure	page 29
3.2.9. Gas mains connection	page 30
3.2.10. Plumbing connection	page 30
3.2.11. Adjustable by-pass	page 31
3.2.12. Power mains connection	page 31
3.2.13. Room thermostat installation (optional)	page 31
3.2.14. Installation of the OpenTherm remote control (optional)	page 31
3.2.15. Installation of the (optional) external probe and sliding temperature operation	page 32
3.3. Filling the system	page 33
3.4. Starting the boiler	page 33
3.4.1. Preliminary checks	page 33
3.4.2. Switching on and off	page 33
3.5. Wiring diagram	page 34
3.6. Adapting to other gases and regulating the burner	page 35
4. Testing the boiler	page 36
4.1. Preliminary checks	page 36
4.2. Switching on and off	page 36
5. Maintenance	page 36
5.1. Maintenance schedule	page 36
5.2. Combustion analysis	page 37
6. Troubleshooting	page 38

LIST OF FIGURES

fig. 1 - Control panel	page 7
fig. 2 - Liquid crystal display	page 8
fig. 3 - Fictitious room temperature	page 12
fig. 4 - Thermoregulation curves	page 12
fig. 5 - Filling tap	page 13
fig. 6 - Dimensions for model BTN	page 16
fig. 7 - Dimensions for model BTFS	page 17
fig. 8 - Plumbing system diagram	page 18
fig. 9 - Installation template	page 22
fig. 10 - Dimensions for connection to a flue gas pipe – model BTN	page 24
fig. 11 - Connection to the stack – model BTN	page 24
fig. 12 - Coaxial air/flue gas discharge pipes - models BTFS	page 26
fig. 13 - Dimensions for connecting the coaxial air/flue gas system – models BTFS	page 26
fig. 14 - OSDOPPIA06 split kit (for models BTFS)	page 27
fig. 15 - Dimensions for connecting split air/flue gas system – models BTFS	page 28
fig. 16 - Opening the casing	page 29
fig. 17 - Chimney-sweep function	page 29
fig. 18 - Examples of points for measuring combustion efficiency	page 29
fig. 19 - Gas mains connection	page 30
fig. 20 - By-pass adjustment	page 31
fig. 21 - Thermoregulation curve adjustment	page 32
fig. 22 - Thermoregulation curves	page 32
fig. 23 - Wiring diagram	page 34
fig. 24 - Gas conversion – gas selection jumper	page 35
fig. 25 - Gas conversion – gas valve modulation coil	page 35
fig. 26 - Gas conversion – pressure intake	page 35
fig. 27 - Gas conversion – control panel settings	page 35
fig. 28 - Gas conversion – gas valve regulation	page 35

LIST OF TABLES

Table 1 - Liquid crystal display during normal operation	page 9
Table 2 - Liquid crystal display in the event of a malfunction	page 9
Table 3 - Operating data - model BTN 24	page 19
Table 4 - Operating data - model BTFS 24	page 19
Table 5 - Operating data - model BTFS 28	page 19
Table 6 - Operating data - model BTFS 32	page 19
Table 7 - Overall data	page 20
Table 8 - Combustion data - model BTN 24	page 20
Table 9 - Combustion data - model BTFS 24	page 20
Table 10 - Combustion data - model BTFS 28	page 20
Table 11 - Combustion data - model BTFS 32	page 20
Table 12 - Relation between the temperature and nominal resistance of probes	page 34

1. USER INSTRUCTIONS

1.1. Control panel

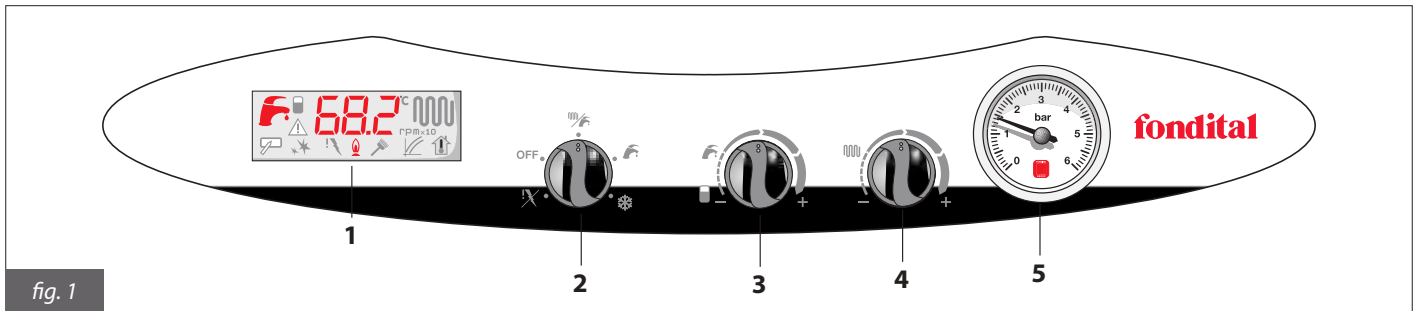

1. Liquid crystal display (LCD)

The LCD displays the boiler status and operating data (see fig. 2).

2. Boiler mode selector

With the selector on RESET , the boiler restarts after activation of the burner shutdown device.

With the selector on OFF, the boiler is in stand-by mode, with the heating and hot water functions disabled.

With the selector on SUMMER , the boiler is ready to produce domestic hot water only.

With the selector on WINTER , the boiler is ready to heat and produce hot water.

With the selector on ANTI-FREEZE , only the anti-freeze function is enabled.

3. DHW temperature regulator

This is used to enable/disable water storage and to set the DHW temperature in the range 35-57°C.

4. CH water temperature regulator

This is used to select the temperature of the water in the heating system in the range 35-78°C.

5. Water pressure gauge

This shows the pressure of the water in the heating system.

1.2. LCD

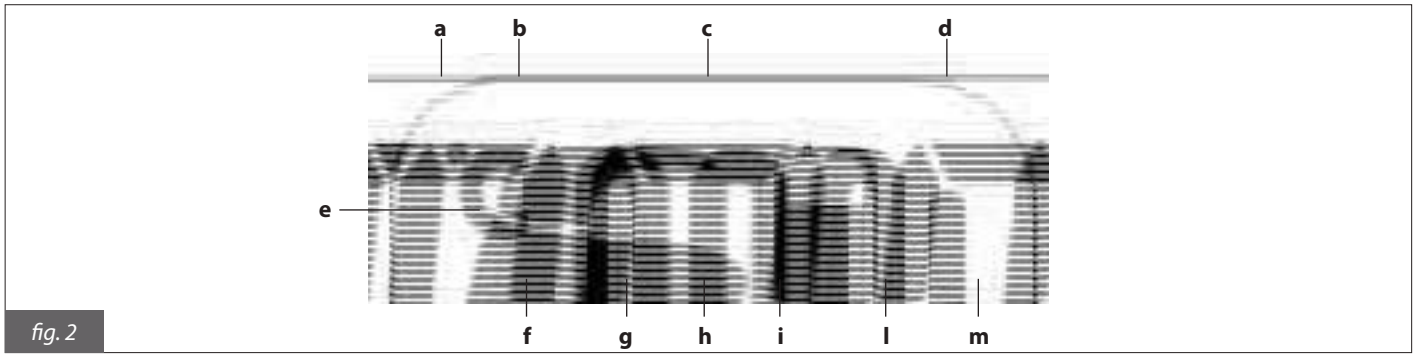

fig. 2

a. DHW indicator (tap symbol)

This comes on when the boiler is in DHW mode.

It flashes when the DHW temperature is being regulated via regulator **3** (fig. 1).

b. Water heater on indicator

This indicator comes on when Aqua Premium system is activated via regulator **3** (fig. 1). Refer to subsection 1.4.3.

c. Alphanumeric indicator

This shows the following:

- boiler status
- CH temperature
- CH temperature setting
- DHW temperature setting
- boiler diagnostics

d. Central heating indicator

This comes on when the boiler is in CH mode.

It flashes when the CH temperature is being regulated via regulator **4** (fig. 1).

e. Boiler shutdown indicator

This comes on when there is a malfunction that cannot be reset via the boiler function selector (**2**, fig. 1).

The problem must be solved before the boiler can be restarted (see 1.5. and following).

f. Ignition power indicator (for fitter only)

Refer to subsection 3.6., for the fitter only.

g. Burner shutdown indicator

This comes on when the burner shutdown device activates due to a malfunction.

To restart the boiler, turn the boiler selector (**2**, fig. 1) to the RESET position  for a few seconds and then back to the desired position (see 1.5. and following).

h. Flame indicator

This comes on when the burner flame is present.

i. Chimney-sweep function indicator (for fitter only)

This comes on when the chimney-sweep function is activated (see 3.2.8.1, for the fitter only).

l. Thermoregulation indicator (for fitter only)

This comes on when the thermoregulation curve is set (see 1.4.7. and 3.2.15., for the fitter only).

m. Fictitious ambient temperature indicator

When an external probe is installed, this indicator flashes when the fictitious ambient temperature is set via regulator **4** (see 1.4.7).

1.3. BOILER STATUS – LCD ACTIVATION CORRESPONDENCE

1.3.1. Normal operation







Boiler selector on OFF	
Boiler selector on ANTI-FREEZE	
Boiler selector on SUMMER or WINTER Aqua Premium system disabled, no function active The water flow temperature is displayed	
Boiler selector on SUMMER or WINTER Aqua Premium system enabled, no function active The water flow temperature is displayed	
Boiler selector on SUMMER or WINTER DWH function active (with Aqua Premium system disabled) The water flow temperature is displayed	
Boiler selector on WINTER CH function active The water flow temperature is displayed	

Table 1

1.3.2. Malfunction











Boiler not powered on	
Boiler shutdown due to flame absence	
Boiler shutdown due to safety thermostat activation	
Boiler shutdown due to flue gas thermostat activation (BTN)	
Boiler shutdown due to air pressure switch activation (BTFS)	
Low system pressure alarm	
CH probe failure	
DHW probe failure	
Storage probe fault	
Gas valve modulator malfunction alarm	
Remote control connection failure	
External probe failure	

Table 2

1.4. Operating the boiler

1.4.1. Switching on



It is presumed that the boiler has been installed by a qualified fitter, it has been used before and is ready to operate correctly.

- Open the gas cock;
- Turn the master switch to ON – the LCD (fig. 1) light up and shows the active function (see table 1) OFF/SUMMER/WINTER/ANTI-FREEZE;
- choose the boiler mode via selector **2** (fig. 1): OFF/SUMMER/WINTER/ANTI-FREEZE;
- Set the temperature for the heating system on regulator **4** (fig. 1);
- Set the DHW temperature on regulator **3** (fig. 1);
- Set the ambient temperature on the (optional) thermostat.

IMPORTANT

If the boiler is not used for a long time, particularly when it runs on propane gas, ignition may be difficult. So, before starting the boiler, switch on a different gas-fired device (e.g. a cooker).

Note that the boiler may still shut down a couple of times. If this happens, turn selector **2 (fig. 1) to the RESET!X position for a few seconds, then back to the desired position.**

1.4.2. CH function

The heating function is only active when the boiler selector (**2**, fig. 1) is on WINTER

The water temperature can be set on regulator **4** (fig. 1).

The temperature range is 35-78°C (from the fully anticlockwise to the fully clockwise position).

During temperature setting, the CH symbol on the LCD flashes and the CH setting is displayed.



When the CH system demands heat, the LCD shows the (fixed) CH symbol and the instant temperature of the CH water.

The burner symbol only shows while the burner is operating.



In order to avoid frequent switching on and off of the heating function, the boiler has a 4-minute waiting time between subsequent ignitions. If, however, the temperature in the system drops below 40°C, this waiting time is cancelled and the boiler reignites.

1.4.3. DHW function

The domestic hot water function is active with the boiler selector **2** (fig. 1) on SUMMER or WINTER

The boiler always gives priority to DHW demand over the CH function.

The boiler is equipped with the AQUA PREMIUM system, which combines the instantaneous production of domestic hot water with a storage function.

1.4.3.1. AQUA PREMIUM system

The boiler comes with a 25-litre stratification storage tank and a secondary plate heat exchanger.

The boiler can either function as a standard instantaneous boiler, when the storage tank is deactivated, or with the innovative Aqua Premium system, when the storage tank is switched on.



The storage tank function is controlled via regulator **3** (fig. 1).

When regulator **3** is turned fully anticlockwise, the storage tank symbol is displayed. Then turn regulator **3** clockwise until a setting of at least 40°C is reached.

To deactivate the storage function, turn regulator 3 fully anticlockwise until the symbol disappears, then back to a setting of at least 40°C.

The temperature range is 35-57°C (from the fully anticlockwise to the fully clockwise position of regulator **3**). During temperature setting, the DHW symbol on the LCD flashes and the water temperature is displayed.



In Aqua Premium mode, when a hot water tap is turned on, the flow switch cuts off the supply of water. The boiler switches on, the cutoff valve opens and the DHW pump activates (the flow rate is fixed).

When DHW demand is less than the pump's flow rate, water to the tap is only supplied by the secondary plate heat exchanger and excess DHW is deviated to the storage tank.

When the DHW demand exceeds the flow rate, water produced by the secondary heat exchanger is added to that from the storage tank. This gives a higher hot water flow than produced by instantaneous boilers with an identical thermal output and traditional ones with a storage tank of the same capacity.

When there is a demand for hot water, the tap symbol (fixed) and the instantaneous water temperature are displayed.

The burner symbol  shows while the burner is in operation.



The boiler can also operate as a standard instantaneous boiler, with the storage tank disabled.

1.4.3.2. Instantaneous production of DHW

When the storage tank is disabled, the boiler operates as a standard instantaneous boiler: the cutoff valve is closed and the DHW pump is off. In this case, DHW demand is met by the secondary heat exchanger only.

The temperature can be selected on regulator **3** in the range 35-57°C (from the fully anticlockwise to the fully clockwise position). During temperature setting, the DHW symbol on the LCD flashes and the DHW temperature is displayed.



The DHW flow rate in litres per minute at the set temperature depends on the boiler's thermal output and the water supply temperature. It can be calculated from the following formula:

$$l = \text{litres of hot water per minute} = \frac{K}{\Delta T}$$

where:

K is

- 334 for model BTN 24
- 341 for model BTFS 24
- 407 for model BTFS 28
- 449 for model BTFS 32

ΔT = DHW temperature – cold water supply temperature

For instance, with model BTFS 24, if the water supplied is 8°C and you want shower water at 38°C, the value of ΔT is:

$$\Delta T = 38^\circ\text{C} - 8^\circ\text{C} = 30^\circ\text{C}$$

and the number of DHW litres per minute available at 38°C is:

$$l = 341 / 30 = 11.4 \text{ [litres per minute]}$$

When there is a demand for hot water, the tap symbol (fixed) and the instantaneous flow water temperature are displayed.

The burner symbol  shows while the burner is in operation.



1.4.4. Anti-freeze function

The boiler comes with an anti-freeze function which is active in SUMMER, WINTER and ANTI-FREEZE modes.



The anti-freeze function protects the boiler only, not the whole heating system. The heating system must be protected by a room thermostat, which is disabled when selector 1 is on ANTI-FREEZE or OFF. So, if you wish to protect the heating system as well, turn selector 2 to WINTER .

The heating system can also be protected effectively from frost by using specific anti-freeze products suitable for multi-metal systems.

Do not use vehicle anti-freeze products. Periodically check the effectiveness of the additive.

When the heating water temperature sensor reads a temperature of 5°C, the boiler switches on at minimum thermal output until the temperature rises to 30°C or 15 minutes have elapsed.

If the boiler shuts down, the pump continues to operate.

When the DHW temperature sensor reads a temperature of 5°C, the boiler switches on at minimum thermal output until the temperature rises to 10°C or 15 minutes have elapsed (the switching valve switches to the DHW position).

If the boiler shuts down, the pump continues to operate.

When the storage tank temperature sensor reads a temperature of 5°C, the boiler switches on at minimum thermal output until the temperature rises to 10°C or 15 minutes have elapsed (the switching valve switches to the DHW position).

If the boiler shuts down, the pump continues to operate.

1.4.5. Pump and valve anti-shutdown function

If the boiler remains inactive and:

- selector **2** is not in the OFF position,
 - the boiler is still connected to the mains supply,
- the pump, the switching valve and the two-way valve activate briefly every 24 hours to keep them efficient.

1.4.6. Operation with (optional) remote control

The boiler can be linked to an (optional, can be supplied by the Producer) remote control, which can be used for setting numerous parameters, including::

- boiler status;
- ambient temperature;
- CH system water temperature;
- DHW system water temperature;
- CH system activation times and storage activation times;
- boiler diagnostics display;
- boiler reset,

and other parameters.

For instructions on how to connect the remote control, refer to subsection 3.2.14.



Only original remote controls supplied by the manufacturer must be used. If non-original remote controls are used, correct operation of the boiler, or of the remote control, cannot be guaranteed.

1.4.7. Operation with an (optional) external probe

The boiler can be connected to an (optional, can be supplied by the Producer) external temperature probe.

When the external temperature has been measured, the boiler automatically regulates the heating water temperature, increasing it when the outside temperature drops and decreasing it when it rises, which improves comfort and saves fuel (this is referred to as *sliding temperature* operation).

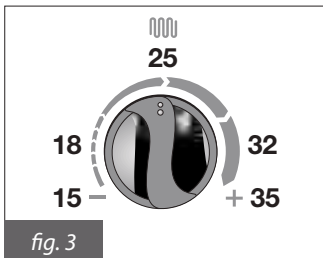

The heating water temperature varies according to a program in the boiler's microprocessor.

When an external probe is installed, regulator **4** (fig. 1) loses its heating water temperature function and becomes a fictitious ambient temperature regulator (fig. 3) for the temperature desired in the areas to be heated.

During temperature setting, the fictitious ambient temperature symbol  flashes and the temperature setting is displayed.

Regulator **4** in the fully anticlockwise position corresponds to a fictitious ambient temperature of 15°C, 9 o'clock corresponds to 18°C, 12 o'clock to 25°C, 3 o'clock to 32°C and the fully clockwise position to 35°C. To get an optimal curve, a setting of approximately 20°C is recommended.

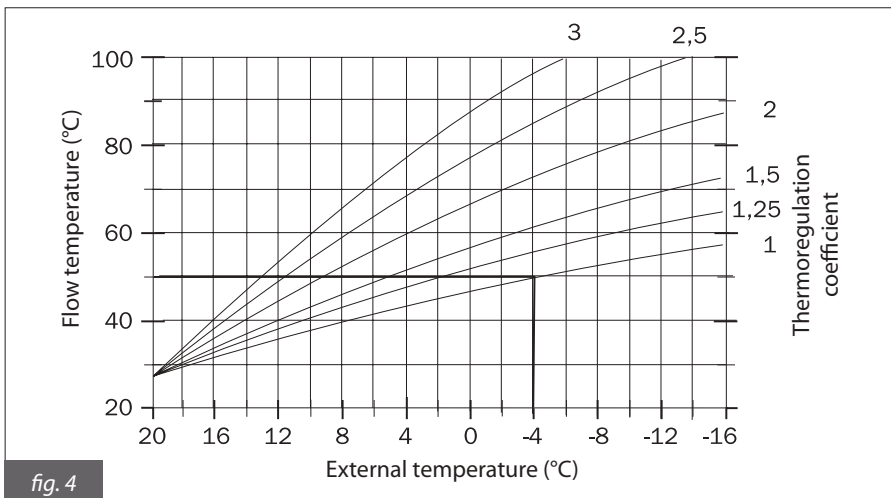

Figure 4 shows the curves for a fictitious ambient temperature of 20°C.

When this value is increased or decreased via regulator **4**, the curves move up or down, respectively, by the same amount.

With a temperature setting of 20°C, for example, if you select the curve corresponding to parameter 1 and the external temperature is -4°C, the flow temperature will be 50°C.



Only original external probes supplied by the manufacturer must be used. If non-original external probes are used, correct operation of the boiler, or of the probe, cannot be guaranteed.

1.5. Boiler shutdown

The boiler shuts down automatically if a malfunction occurs.

Refer to Tables 1 and 2 to identify the boiler operating mode.

Refer to Table 2 and section 6 to identify possible causes of the shutdown. The troubleshooting section is at the end of this manual. Below is a list of kinds of shutdown and the procedure to follow in each.

1.5.1. Burner shutdown

If the burner shuts down as there is no flame, the burner shutdown symbol !X is displayed and code E01 flashes.



If this happens, proceed as follows:

- check that the gas cock is open and light a gas ring for example to check the gas supply;
- if the gas supply is normal, turn selector **2** to the reset !X position for a few seconds, then back to the desired position. If after three attempts the burner still fails to ignite, contact an Authorised Service Centre or a qualified service engineer.

If the burner shuts down frequently, there is a recurring malfunction, so contact an Authorised Service Centre or a qualified service engineer.

1.5.2. Shutdown due to overheating

If the water temperature is too high, the boiler will shut down. The burner shutdown symbol !X is displayed and code E02 flashes. Contact an Authorised Service Centre or a qualified service engineer.



1.5.3. Shutdown due to air/flue gas system malfunction

If the air/flue gas system malfunctions, the boiler shuts down. The burner shutdown symbol !X is displayed and code E03 (for model BTN) or code E20 (for model BTFS) flashes.



Contact an Authorised Service Centre or a qualified service engineer.

1.5.4. Shutdown due to insufficient water pressure

If the water pressure in the heating system is too low, the water pressure switch activates and the boiler shuts down. The boiler shutdown symbol Δ is displayed and code E04 flashes.



Open the filling tap to fill the system (fig. 5). The pressure with the boiler cold must be 1-1.3 bar. Proceed as follows to restore the correct water pressure:

- Turn the filling tap (fig. 5) anticlockwise to allow water to enter the boiler.
- Keep the tap open until the pressure gauge shows a value of 1-1.3 bar.
- Turn the tap clockwise to close it.
- If the boiler still does not work, turn selector **2** to the RESET !X position for a few seconds, then back to the desired position.

If the boiler still fails to operate, contact an Authorised Service Centre or a qualified service engineer.



Make sure you close the tap carefully after filling.

If you do not, when the pressure increases, the safety valve may activate and discharge water.

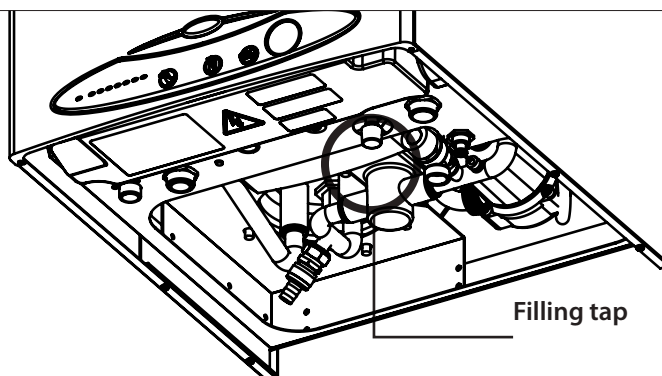

fig. 5

1.5.5. Alarm due to temperature probe malfunction

If the burner shuts down due to malfunction of the temperature probes, the boiler shutdown symbol  is displayed and the following codes may flash:

- E05, CH probe: the boiler does not work;
- E06, DHW probe: the boiler only operates in CH mode, not DHW mode;
- E12, storage probe; the boiler operates in CH and instantaneous DHW mode, not Aqua Premium mode.

Contact an Authorised Service Centre or a qualified service engineer.

1.5.6. Alarm due to external probe malfunction (optional)

If the (optional) external temperature probe malfunctions, the boiler shutdown symbol  is displayed and code E23 flashes.

The boiler will continue to operate, but the sliding temperature function is deactivated. The temperature of the CH water is regulated according to the position of regulator **4** (fig. 1), which in this case loses its function as a fictitious ambient temperature regulator (see 1.4.7.).

Contact an Authorised Service Centre or a qualified service engineer.

1.5.7. Alarm due to gas valve modulator malfunction

If the gas valve modulator malfunctions, the boiler shutdown symbol  is displayed and code E16 flashes. The boiler will continue to operate, but at the minimum power available.

Contact an Authorised Service Centre or a qualified service engineer.

1.5.8. Alarm due to (optional) remote control connection malfunction

The boiler recognises whether or not there is a remote control (optional). If the remote control is connected but the boiler does not receive instructions, the boiler shutdown symbol  is displayed and code E22 flashes.

The boiler will continue to operate according to the settings on the control panel (fig. 1) and ignore the remote control settings.

Contact an Authorised Service Centre or a qualified service engineer.

1.6. Maintenance

The boiler must be serviced periodically as indicated in the relevant section of this manual.

Correct maintenance of the boiler will allow it to work efficiently, without harming the environment, and in complete safety. Maintenance and repairs must be performed by qualified personnel.

The user is strongly advised to have the boiler serviced and repaired by one of the Manufacturer's fully qualified and authorised Service Centres.

Refer to Section 5 – Maintenance for detailed instructions.

The user may only clean the external casing of the boiler, using ordinary furniture cleaning products. Do not use water.

1.7. Notes for the user

The user may only access parts of the boiler that can be reached without using special equipment or tools. The user is not authorised to remove the boiler casing or to operate on any internal parts.

No one, including qualified personnel, is authorised to modify the boiler.

The manufacturer cannot be held liable for damage or injury due to tampering of the boiler or improper intervention.

If the boiler remains inactive and the power supply is switched off for a long time, it may be necessary to reset the pump.

This involves removing the casing and accessing internal parts, so it must only be done by suitably qualified personnel.

Pump failure can be avoided by adding to the water filming additives suitable for multi-metal systems.

2. TECHNICAL FEATURES AND DIMENSIONS

2.1. Technical features

This boiler has a built-in multi-gas atmospheric burner.

All versions come with electronic ignition, an ionization flame and an AQUA PREMIUM system for the production of DHW, with a 25-litre stratification storage tank and a secondary plate heat exchanger.

The following versions are available:

BTN 24 a natural-draught open-flue boiler for CH and DHW, heat output 23.31 kW

BTFS 24 a forced-draught balanced-flue boiler for CH and DHW, heat output 23.8 kW

BTFS 28 a forced-draught balanced-flue boiler for CH and DHW, heat output 28.4 kW

BTFS 32 a forced-draught balanced-flue boiler for CH and DHW, heat output 31.3 kW

These boilers meet all the requirements in the country of destination indicated on the rating plate.

Installation in a different country may cause a hazard for people, animals and property.

The main technical features of the boiler are given below.

Construction characteristics

- IPX4D electrically protected control panel
- Electronic safety board and integrated modulation
- Electronic ignition with separate igniter and ionization flame detector
- Stainless steel multi-gas atmospheric burner
- Modulating double-shutter gas valve
- High output monothermal copper heat exchanger
- DHW stainless steel plate heat exchanger
- 25-litre vertical stratification storage tank with magnesium anode
- Motorized switching valve
- 3-speed CH pump with built-in deaerator
- DHW pump
- 8-litre CH expansion vessel (models BTN 24 and BTFS 24) and 10-litre expansion vessel (models BTFS 28 and BTFS 32)
- 2-litre DHW expansion vessel
- Combustion fan (BTFS)
- Low-water pressure switch
- DHW priority flow switch
- DHW filter
- Adjustable bypass
- Boiler filling and drain cocks
- DHW, CH and storage tank temperature probes
- Safety limit thermostat
- Flue gas thermostat (BTN)
- Differential pressure switch (BTFS)
- 3-bar CH safety valve
- 6-bar DHW safety valve

User interface

- Liquid crystal display showing the boiler operating status
- Mode selector: RESET, OFF, WINTER, SUMMER and ANTI-FREEZE
- CH water temperature regulator: 35-78°C
- DHW water temperature regulator: 35-57°C (also used to (de)activate the AQUA PREMIUM system)
- Water pressure gauge

Operating features

- CH electronic flame modulation with timer-controlled rising ramp (50 seconds)
- DHW electronic flame modulation
- DHW priority function
- CH anti-freeze function (ON 5°C; OFF 30°C or after 15 minutes of operation)
- DHW anti-freeze function (ON 5°C; OFF 10°C or after 15 minutes of operation)
- Storage tank anti-freeze function (ON 5°C; OFF 10°C or after 15 minutes of operation)
- Anti-legionella function
- Timer-controlled chimney-sweep function (15 minutes)
- Ignition flame propagation function
- CH maximum heat input adjusting trimmer
- Ignition heat input adjusting trimmer
- Timer-controlled room thermostat (240 seconds with CH flow temperature >40°C)
- Heating pump post-circulation function in CH, ANTI-FREEZE and CHIMNEY-SWEEP mode (180 seconds)
- Heating pump post-circulation function in DHW mode (6 seconds, only with selector 2 on WINTER)
- Post-circulation function for heating temperature >85°C (30 seconds).
- Post-ventilation safety function (ON 95°C; OFF 90°C).
- Anti-blocking function for CH pump, DHW pump, switching valve and 2-way valve (6-second operation every 24 hours of boiler inactivity)
- Ready for connection to a room thermostat (optional)
- Ready for operation with an external probe (optional, supplied by the manufacturer)
- Ready for operation with an OpenTherm remote control (optional, supplied by the manufacturer)

2.2. Dimensions

Mod. BTN

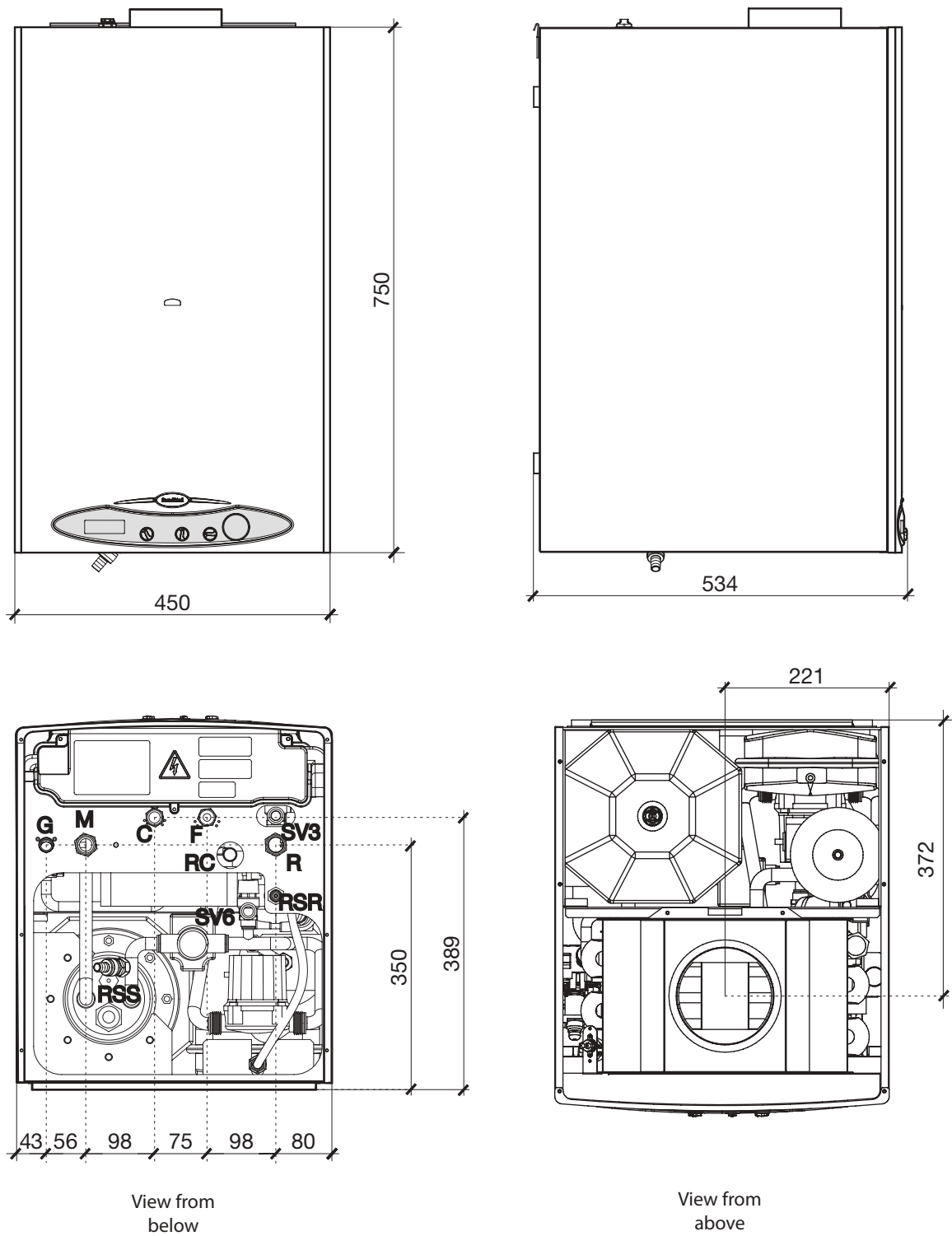

- G** Gas inlet
- M** CH flow
- C** DHW outlet
- F** Cold water inlet
- R** CH return

- RC** Filling tap
- RSR** CH drain tap
- RSS** Storage/DHW drain tap
- SV3** 3-bar safety valve (CH)
- SV6** 6-bar safety valve (DHW)

fig. 6

Mod. BTFS

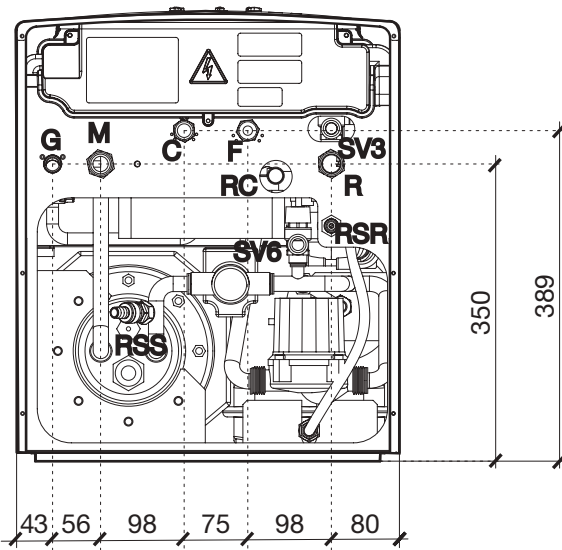
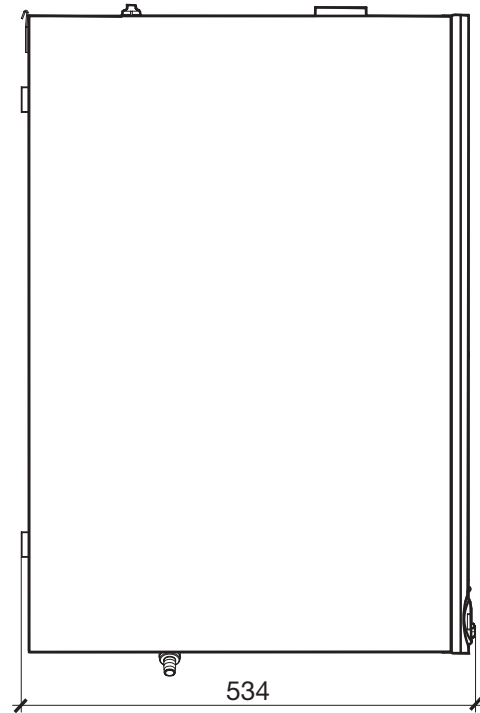
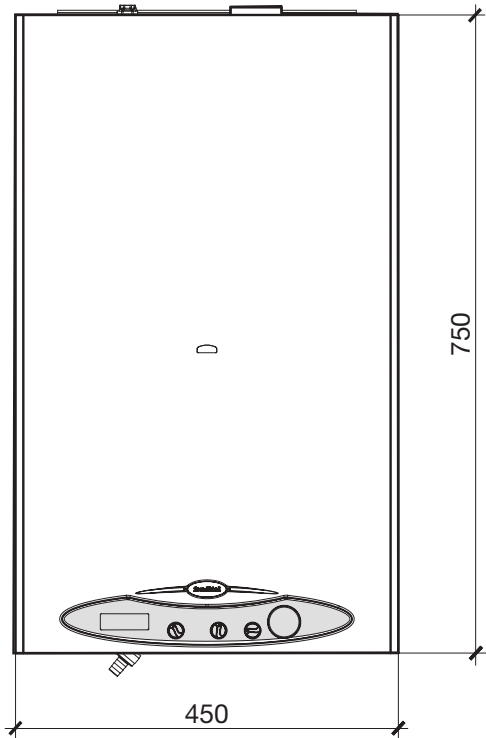

View from
below

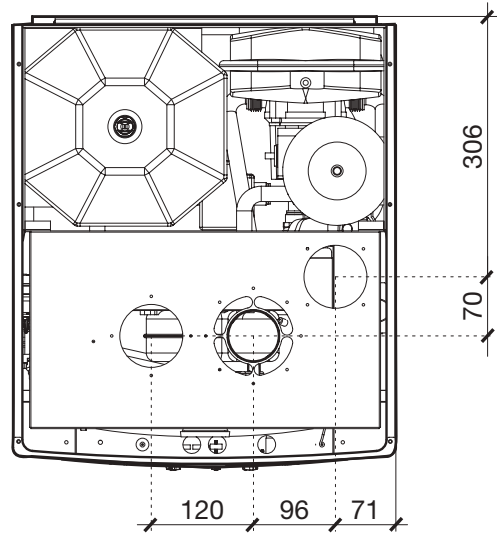

View from
above

- G** Gas inlet
- M** CH flow
- C** DHW outlet
- F** Cold water inlet
- R** CH return

- RC** Filling tap
- RSR** CH drain tap
- RSS** Storage/DHW drain tap
- SV3** 3-bar safety valve (CH)
- SV6** 6-bar safety valve (DHW)

fig. 7

2.3. Boiler layout

- TS** LIMIT THERMOSTAT
- V3V** MOTORIZED 3-WAY VALVE
- VM** MOTORIZED 2-WAY VALVE
- PR** CH PUMP WITH DEAERATOR
- PS** DHW PUMP
- F** PRIORITY FLOW SWITCH

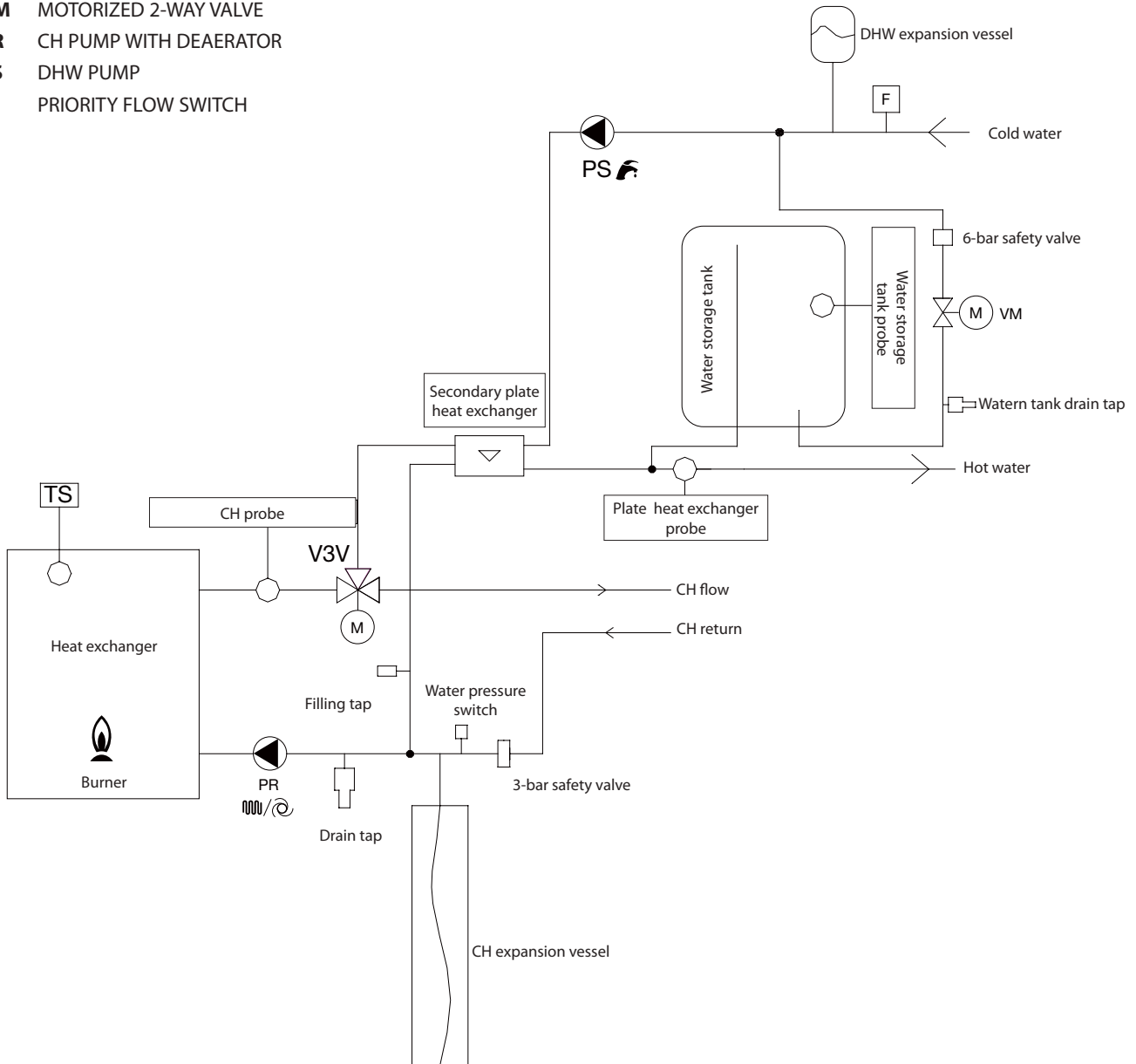

fig. 8

2.4. Operating data

Burner pressures must be checked after 3 minutes of boiler operation.

BTN 24							
Fuel	Max. heat input (kW)	Min. heat output (kW)	Max. heat output (kW)	Gas mains pressure (mbar)	Nozzle diameter (mm)	Burner pressure (mbar)	
						min	max
Methane gas G20	25.7	9.85	23.31	20	1.25	2.5	13.0
Butane gas G30	25.7	9.85	23.31	29	0.77	5.3	27.0
Propane gas G31	25.7	9.85	23.31	37	0.77	6.6	35.5

Table 3

Instantaneous DHW supply ΔT 45 K = 7.4 l/min
 Instantaneous DHW supply ΔT 40 K = 8.4 l/min
 Instantaneous DHW supply ΔT 35 K = 9.5 l/min

Instantaneous DHW supply ΔT 30 K = 11.1 l/min
 Instantaneous DHW supply ΔT 25 K = 13.4 l/min

BTFS 24							
Fuel	Max. heat input (kW)	Min. heat output (kW)	Max. heat output (kW)	Gas mains pressure (mbar)	Nozzle diameter (mm)	Burner pressure (mbar)	
						min	max
Methane gas G20	25.5	9.5	23.8	20	1.25	2.5	13.5
Butane gas G30	25.5	9.5	23.8	29	0.77	4.2	27.0
Propane gas G31	25.5	9.5	23.8	37	0.77	5.5	35.7

Table 4

Instantaneous DHW supply ΔT 45 K = 7.6 l/min
 Instantaneous DHW supply ΔT 40 K = 8.5 l/min
 Instantaneous DHW supply ΔT 35 K = 9.7 l/min

Instantaneous DHW supply ΔT 30 K = 11.4 l/min
 Instantaneous DHW supply ΔT 25 K = 13.6 l/min

BTFS 28							
Fuel	Max. heat input (kW)	Min. heat output (kW)	Max. heat output (kW)	Gas mains pressure (mbar)	Nozzle diameter (mm)	Burner pressure (mbar)	
						min	max
Methane gas G20	30.5	10.0	28.4	20	1.35	1.3	11.5
Butane gas G30	30.5	10.0	28.4	29	0.80	3.5	28.5
Propane gas G31	30.5	10.0	28.4	37	0.80	4.5	33.0

Table 5

Instantaneous DHW supply ΔT 45 K = 9.0 l/min
 Instantaneous DHW supply ΔT 40 K = 10.2 l/min
 Instantaneous DHW supply ΔT 35 K = 11.6 l/min

Instantaneous DHW supply ΔT 30 K = 13.6 l/min
 Instantaneous DHW supply ΔT 25 K = 16.3 l/min

BTFS 32							
Fuel	Max. heat input (kW)	Min. heat output (kW)	Max. heat output (kW)	Gas mains pressure (mbar)	Nozzle diameter (mm)	Burner pressure (mbar)	
						min	max
Methane gas G20	33.6	12.2	31.3	20	1.40	1.7	9.2
Butane gas G30	33.6	12.2	31.3	29	0.78	4.1	28.2
Propane gas G31	33.6	12.2	31.3	37	0.78	5.5	34.8

Table 6

Instantaneous DHW supply ΔT 45 K = 10.0 l/min
 Instantaneous DHW supply ΔT 40 K = 11.2 l/min
 Instantaneous DHW supply ΔT 35 K = 12.8 l/min

Instantaneous DHW supply ΔT 30 K = 15.0 l/min
 Instantaneous DHW supply ΔT 25 K = 17.9 l/min

Note: DHW supply refers to instantaneous production.

2.5. Technical specifications

		BTN 24	BTFS 24	BTFS 28	BTFS 32
Boiler category	-	II2H3+	II2H3+	II2H3+	II2H3+
Number of burner nozzles	-	12	12	13	15
Minimum CH pressure	bar	0.5	0.5	0.5	0.5
Maximum CH pressure	bar	3	3	3	3
Minimum DHW pressure	bar	0.5	0.5	0.5	0.5
Maximum DHW pressure	bar	8	8	8	8
DHW specific flow rate (ΔT 30K)	l/10'	155	160	180	200
Power supply – voltage/frequency	V ~ Hz	230 ~ 50	230 ~ 50	230 ~ 50	230 ~ 50
Power mains fuse	A	2	2	2	2
Maximum power consumption	W	140	180	200	230
Index of protection	IP	X4D	X4D	X4D	X4D

Methane gas consumption at maximum flow (*)	m3/h	2.72	2.70	3.23	3.46
Butane gas consumption at maximum flow	kg/h	2.02	2.01	2.40	2.62
Propane gas consumption at maximum flow	kg/h	1.99	1.98	2.37	2.51

Maximum CH operating temperature	°C	83	83	83	83
Maximum DHW operating temperature	°C	62	62	62	62
Total capacity of expansion vessel	l	8	8	10	10
Maximum recommended CH system capacity (**)	l	160	160	200	200

Table 7

(*) Value refers to 15°C - 1013 mbar.

(**) Maximum water temperature = 83°C. Expansion vessel pressure pre-charge = 1 bar.

BTN 24		Max output	Min output	30% output
Outer casing heat loss	%	0.8	0.8	-
Flue system heat loss with burner on	%	8.5	9.7	-
Flue system mass capacity	g/s	16.2	13.7	-
Flue temp. - Air temp.	°C	85	50	-
CO ₂	%	6.2	3.0	-
Boiler efficiency rate	%	90.7	89.5	88.7
Efficiency class (acc. to 92/42/CE)	-	**		
NOx emissions class	-	2		

Table 8

BTFS 24		Max output	Min output	30% output
Outer casing heat loss	%	0.23	0.23	-
Flue system heat loss with burner on	%	6.57	9.67	-
Flue system mass capacity	g/s	14.0	14.4	-
Flue temp. - Air temp.	°C	75	67	-
CO ₂	%	7.2	2.8	-
Boiler efficiency rate	%	93.2	90.1	90.2
Efficiency class (acc. to 92/42/CE)	-	***		
NOx emissions class	-	2		

Table 9

BTFS 28		Max output	Min output	30% output
Outer casing heat loss	%	0.23	0.23	-
Flue system heat loss with burner on	%	6.67	8.87	-
Flue system mass capacity	g/s	18.2	18.7	-
Flue temp. - Air temp.	°C	75	45	-
CO ₂	%	6.6	2.1	-
Boiler efficiency rate	%	93.1	90.9	90.4
Efficiency class (acc. to 92/42/CE)	-	***		
NOx emissions class	-	2		

Table 10

BTFS 32		Max output	Min output	30% output
Outer casing heat loss	%	0.23	0.23	-
Flue system heat loss with burner on	%	6.67	9.77	-
Flue system mass capacity	g/s	18.9	19.2	-
Flue temp. - Air temp.	°C	92	45	-
CO ₂	%	6.9	2.5	-
Boiler efficiency rate	%	93.1	90.0	90.3
Efficiency class (acc. to 92/42/CE)	-	***		
NOx emissions class	-	2		

Table 11

3. INSTRUCTIONS FOR THE FITTER

3.1. Installation standards

This is a II2H3+ boiler which must be installed in compliance with the applicable laws and standards in the country of installation.

3.2. Installation



Only original accessories and spare parts supplied by the manufacturer must be used for installation and maintenance.

If non-original accessories and spare parts are used, correct operation of the boiler cannot be guaranteed.

3.2.1. Packaging

The boiler is supplied in a sturdy cardboard box. Unwrap the boiler, then check that everything is complete and nothing is damaged.

All the packaging materials can be recycled and should be disposed of in appropriate waste collection bins. Keep the packaging out of the reach of children as it may be a source of danger.

The manufacturer cannot be held liable for damage or injury due to non-observance of the above rules.

Contents of the box:

- kit of copper pipes for connecting the boiler to the CH and DHW system and the gas mains;
- one metal wall bracket;
- a bag containing:
 - a) this installation, use and maintenance manual;
 - b) a wall-mounting template (fig. 9);
 - c) 4 screws and wall plugs for fixing the boiler to the wall;
 - d) for model BTFS 24: three flue gas diaphragms (diameters 40, 42 and 45 mm);
 - e) for model BTFS 28: three flue gas diaphragms (diameters 44, 47 and 49 mm);
 - f) for model BTFS 32: four flue gas diaphragms (diameters 45, 47, 49 and 51 mm);
 - g) for models BTFS: two closing caps with gaskets (fig. 12).

3.2.2. Deciding where to install the boiler

There are several points to take into account when deciding where to install the boiler.

- Refer to the instructions in subsections 3.2.5., 3.2.6. and 3.2.7.
- Make sure the wall is strong enough to support the boiler – avoid lightweight partition walls.
- Do not install the boiler above any equipment that may affect operation (e.g. cookers generating greasy vapour or washing machines).
- Do not install the natural draught model (BTN) in a room where the atmosphere is corrosive or very dusty, such as a hairdressing salon or laundry, as this would greatly reduce the life of the component parts.

3.2.3. Positioning the boiler

Each boiler is provided with a paper template (fig. 9) that can be used when designing the plumbing system and prior to installation of the boiler to position the connections to the CH system, the DHW system, the gas mains and the air/flue gas pipe.

The template is made of heavy-duty paper. Fix it in position on the wall, using a spirit level. It provides all the indications required to drill the holes for fixing the boiler to the wall, which is done using two screws and wall plugs.

The lower section of the template shows where to mark the exact spots where the fittings are to be positioned for connecting the boiler to the gas, cold water, DHW flow, CH flow and return pipes.

The upper section shows where to mark the exact spots for positioning the air/flue gas pipes.



Since the temperature of the wall on which the boiler is fitted and the outside temperature of the coaxial air intake and flue gas outlet pipes are less than 60°C, a minimum distance between flammable walls is not required.

For boilers with split air and flue gas pipes that run along or through flammable walls, insulation must be laid between the wall and the flue gas outlet pipe.

WALL-MOUNTING TEMPLATE

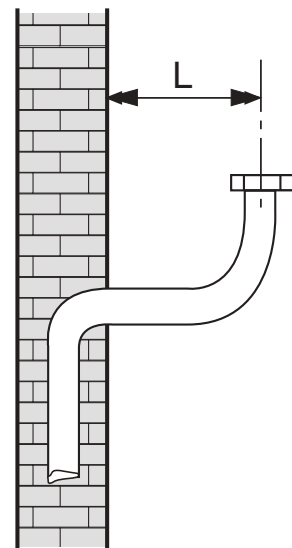
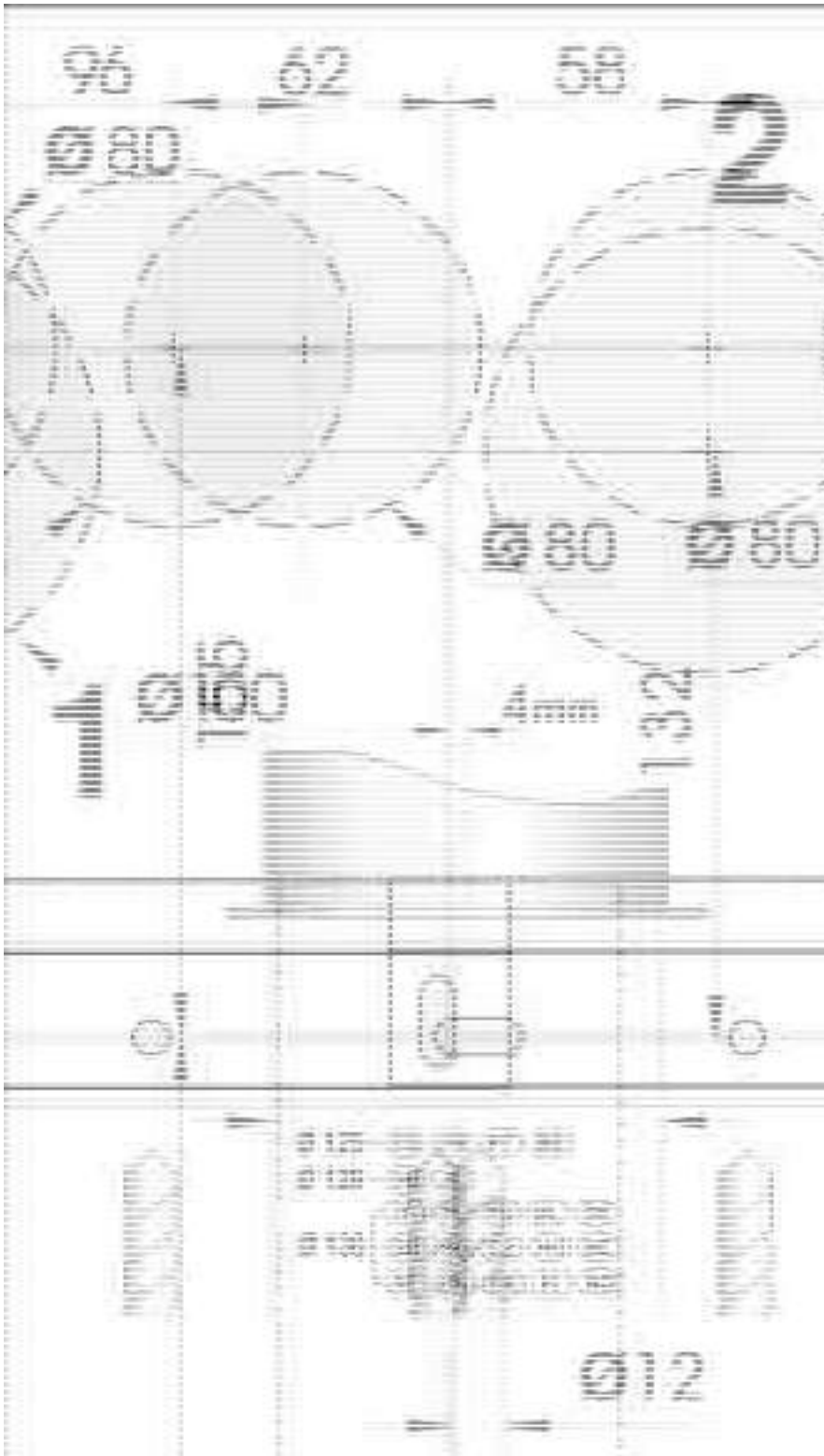

	Fitting Ø	Copper pipe Ø (mm)	L (mm)
M = CH flow	3/4"	18	349
C = DHW flow	1/2"	14	389
G = Gas	1/2"	18	349
F = Cold water	1/2"	14	389
R = CH return	3/4"	18	349

fig. 9

3.2.4. Installing the boiler

Before connecting the boiler to the CH and DHW system, it needs to be cleaned thoroughly.

Before putting a NEW system into service, clean thoroughly to remove any metal residue left over from manufacturing and welding processes, and any oil and grease deposits. This is because if they got into the boiler they would damage it or interfere with operation.



Before putting a RENOVATED system into service (addition of radiators, replacement of the boilers, etc.), clean thoroughly to remove any sludge and foreign bodies.

This can be done using suitable non-acidic products available from the market. Do not use solvents as they could damage the components.

In any heating system (new or renovated), add to the water in a suitable concentration specific corrosion inhibitors for multi-metal systems, which form a protective film on the internal surfaces.

The manufacturer declines all liability for damage or injury caused by failure to comply with these instructions.

Proceed as follows to install the boiler:

- Fix the template (fig. 9) onto the wall, as indicated in subsection 3.2.3.
- Drill four 12 mm holes in the wall to accommodate the wall plugs.
- If necessary, drill holes in the wall for the air/flue gas pipes.
- Fix the bracket onto the wall using the screws and wall plugs provided.
- Position the fittings for connecting the gas (G), cold water (F), DHW flow (C), CH flow (M) and CH return (R) pipes, as shown on the template (lower section).
- Provide a system for relieving the 3-bar and 6-bar safety valves.
- Hang the boiler on the bracket.
- Connect the boiler to the mains pipes using the pipe kit provided (see 3.2.9. and 3.2.10.).
- Connect the boiler to the air/flue gas system (see 3.2.5., 3.2.6. and 3.2.7.);
- Connect up to the power supply, and connect the (optional) room thermostat and any other accessories (see below).

3.2.5. Boiler room ventilation



It is mandatory to install the boiler in a suitable room in accordance with the applicable laws and standards in the country of installation, which are considered as fully transcribed in this manual.

BTN model has an open combustion chamber and needs to be connected to a flue pipe. The combustion air is drawn from the room in which the boiler is installed.

BTFS models have a sealed combustion chamber, therefore specific recommendations concerning air ventilation openings do not apply. The same goes for the boiler room itself.

3.2.6. Air/flue gas system for natural draught boilers (BTN)

For regulations covering flue gas emissions into the atmosphere refer to the applicable laws, which are considered an integral part of this manual.

The boiler is equipped with an automatic-reset safety device that prevents flue gas from entering the boiler room.



If the system malfunctions, this device shuts the boiler down (see 1.5.3.).

The safety device must never be tampered with or deactivated.

If the boiler shuts down repeatedly, the flue gas discharge pipe needs to be checked by an Authorized Service Centre or a qualified person as it may be blocked or unsuitable.

The manufacturer declines all liability for damage caused by wrong installation or use of the boiler, modifications or failure to comply with the manufacturer's instructions and installation standards.

Connecting to the stack

The stack plays a vital role in efficient operation of the system. It must meet the following requirements:

- It must be made of waterproof material that is resistant to the temperature of the flue gas and any condensate formed.
- It must have sufficient mechanical resistance and low thermal conductivity.
- It must be perfectly airtight.
- It must be as vertical as possible and the terminal must have a chimney cap that guarantees efficient and constant discharge of the products of combustion.
- The diameter of the stack must not be less than the diameter at the start of the boiler flue; for square or rectangular stacks, the inside cross section must be 10% greater than that at the point of connection to the draught diverter.
- Starting from the boiler, the coupling must have a vertical section of a length that is no less than twice the diameter before entry in the stack.

Direct discharge outside

Natural draught boilers can discharge the products of combustion straight into the atmosphere by means of a pipe through the perimetral wall of the building to which a draught terminal is connected.

The discharge pipe must also comply with the following requirements:

- the sub-horizontal part inside the building must be reduced to a minimum (no more than 1000 mm);
- there must not be more than 2 changes in direction;
- it must be connected to a single boiler;
- the section passing through the wall must be protected by a duct that is closed at the inside end and open towards the outside;
- the final section must have a draught terminal fitted onto it and project from the building by the equivalent of at least 2 diameters;
- the draught terminal must be at least 1.5 metres above the discharge pipe fitting on the boiler (see fig. 11).

3.2.7. Air/flue gas system for forced draught boilers (BTFS)



The boiler is equipped with an automatic-reset safety device that prevents flue gas from entering the boiler room. If the system malfunctions, this device shuts the boiler down (see 1.5.3.). The safety device must never be tampered with or deactivated. If the boiler shuts down repeatedly, the air intake and flue gas discharge pipes need to be checked by an Authorized Service Centre or a qualified person as they may be blocked or unsuitable.

The manufacturer declines all liability for damage caused by wrong installation or use of the boiler, modifications or failure to comply with the manufacturer's instructions and installation standards.

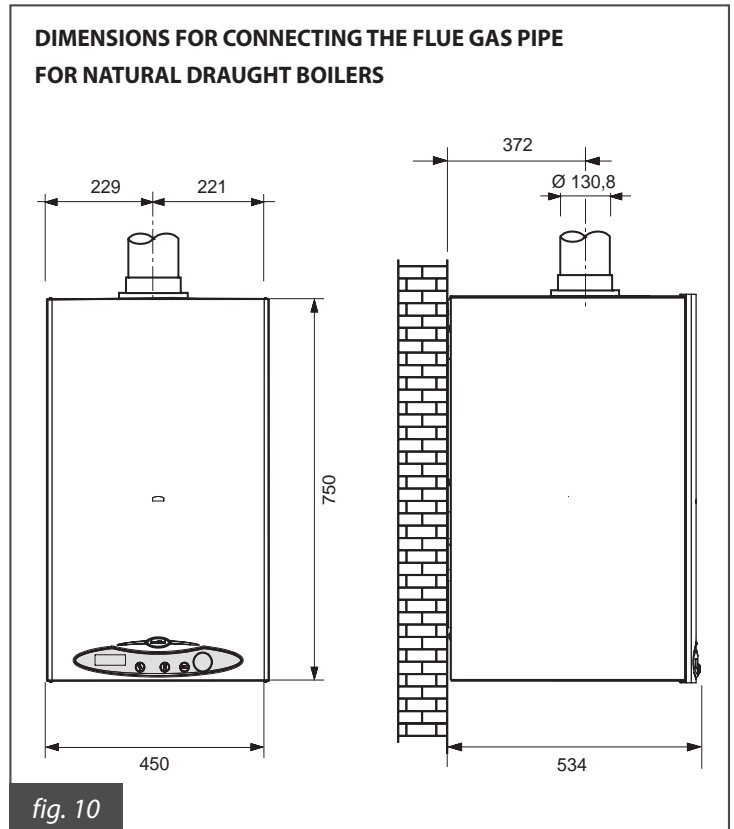

fig. 10

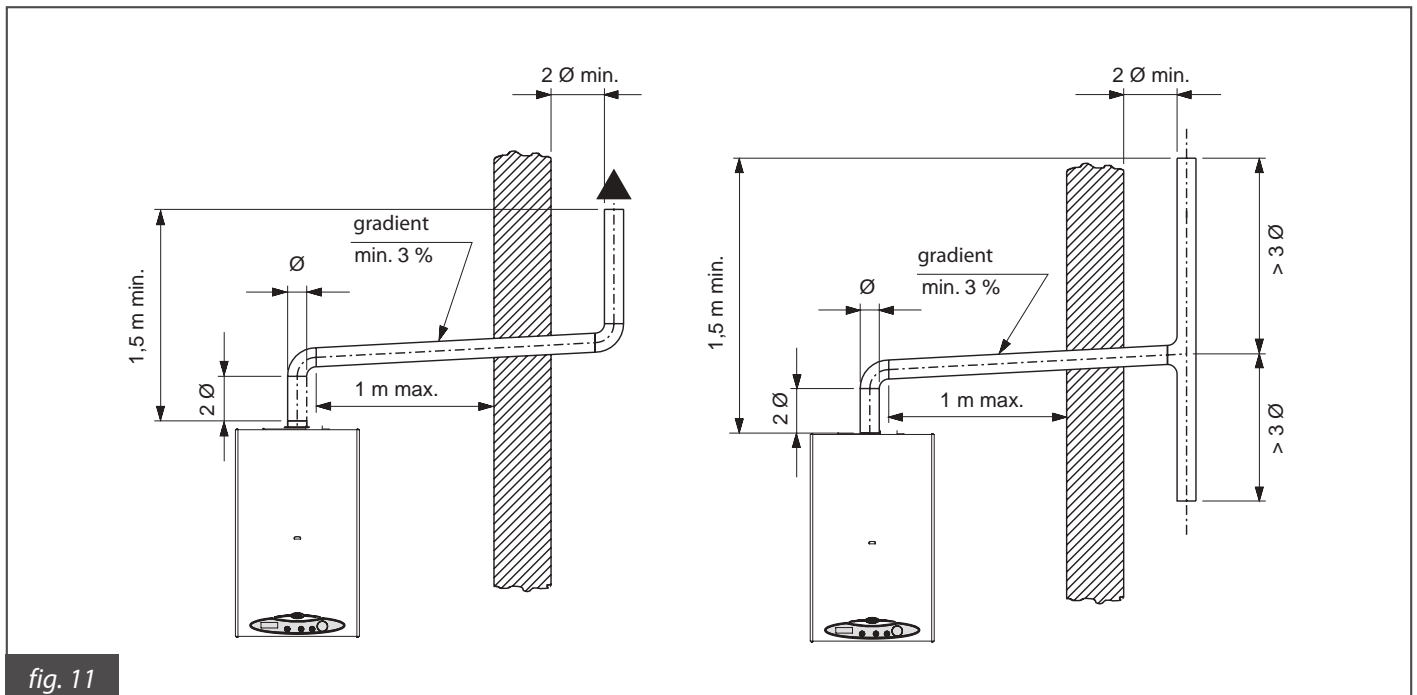
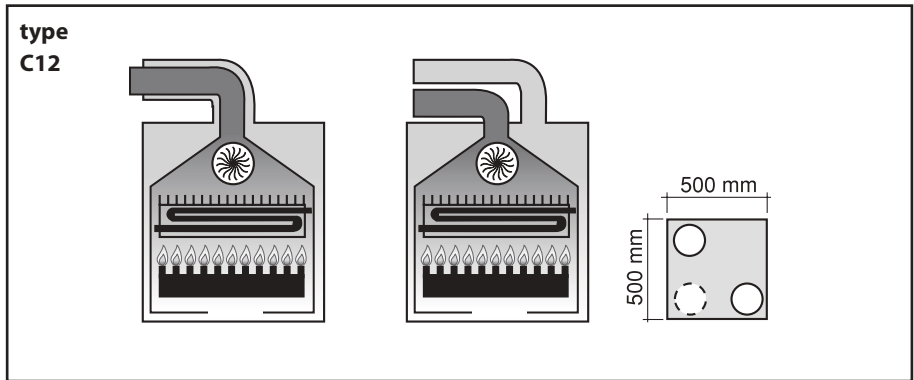
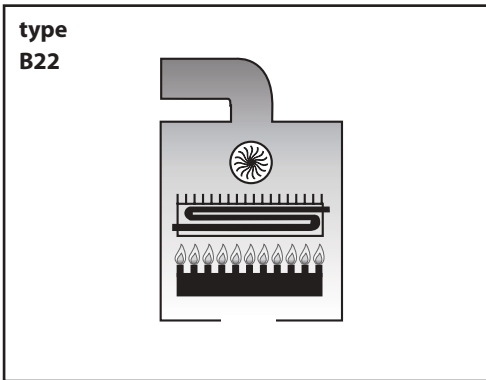
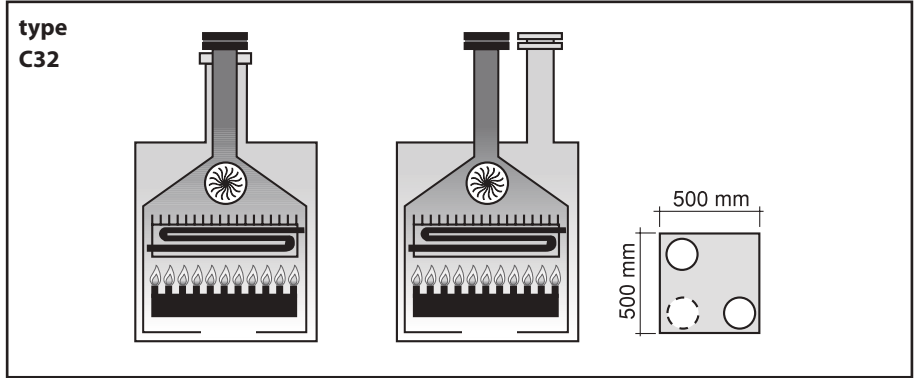

fig. 11



3.2.7.1. Air/flue gas pipe configuration: B22, C12, C32, C42, C52, C82

B22 This boiler is intended for connection to an existing flue system either inside or outside the boiler room. Combustion air is drawn straight from the boiler room itself and flue gas is conveyed to the outside. The boiler **must not** be fitted with an anti-wind gust system; it must be equipped with a fan mounted after the combustion chamber.



C12 This boiler is intended for connection to horizontal flue gas and air-intake pipes connected to the outside by means of coaxial or split pipes. The distance between the air intake pipe and the flue gas pipe must be at least 250 mm and both terminals must be positioned in a 500mm-side square area.

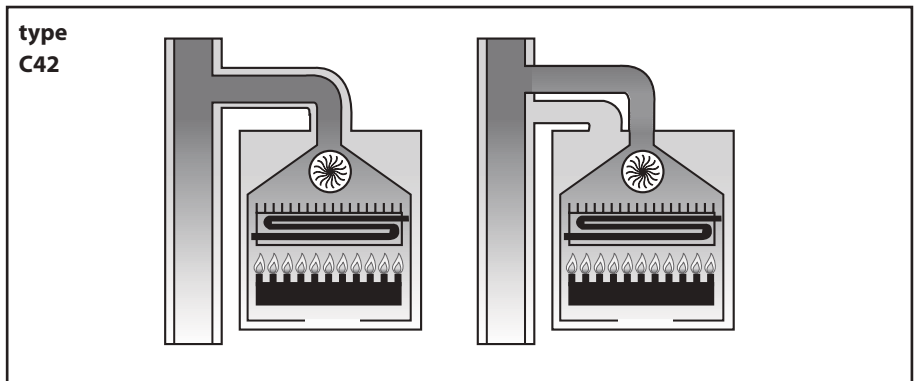

C32 This boiler is intended for connection to vertical flue gas and air-intake pipes connected to the outside by means of coaxial or split pipes. The distance between the air intake pipe and the flue gas pipe must be at least 250 mm and both terminals must be positioned in a 500mm-side square area.

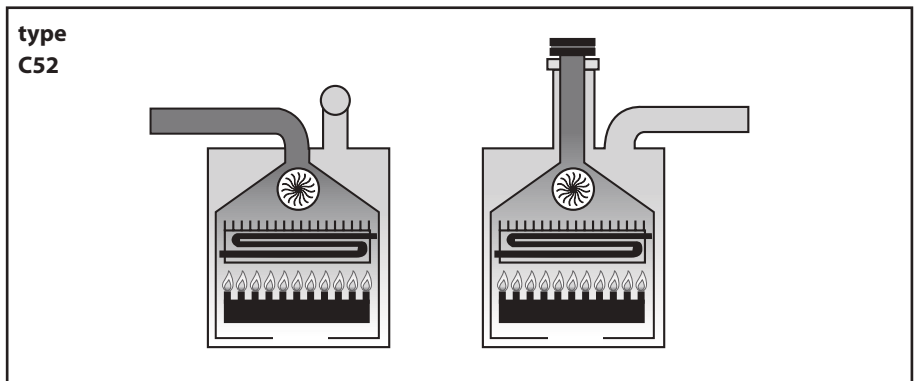

C42 This boiler is intended for connection to a common chimney pipe system that includes two pipes, one for the air intake and the other for flue gas discharge. These pipes may be coaxial or split. **The flue gas chimney system must comply with current standards.**

C52 Boiler with separate pipes for air intake and flue gas. **Air and flue gas may have different discharge pressures. Air and flue gas terminals must not face each other from opposite walls.**

C82 This boiler is intended to be connected to a combustion air-intake terminal and to a single flue gas terminal or to a common chimney. **The flue gas chimney system must comply with current standards.**

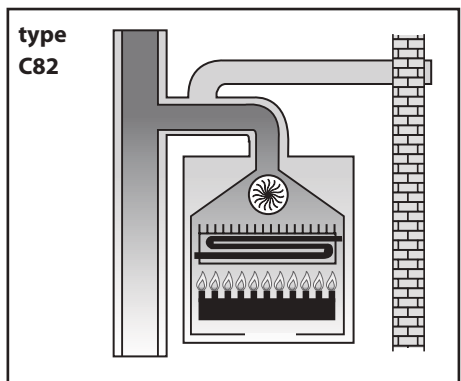

3.2.7.2. Air/flue gas system with 100/60 mm diameter coaxial pipes

C12 - C32 - C42 installation types

BTFS 24

The minimum acceptable length of pipes is 0.5 metres plus one elbow.
The maximum acceptable length of pipes is 4 metres plus one elbow.
In the presence of additional elbows, the maximum acceptable length must be reduced by 1 metre for each elbow installed.

Choosing the right diaphragm supplied with the boiler

Pipe length (m)	Diameter of the flue gas diaphragm (mm)
$0.5 \leq L \leq 1$	Ø 40
$1 < L \leq 3$	Ø 45
$3 < L \leq 4$	No diaphragm required

BTFS 28

The minimum acceptable length of pipes is 0.5 metres plus one elbow.
The maximum acceptable length of pipes is 4 metres plus one elbow.
Maximum acceptable length must be reduced by one metre for each additional elbow installed.

Choosing the right diaphragm supplied with the boiler

Pipe length (m)	Diameter of the flue gas diaphragm (mm)
$0.5 \leq L \leq 3$	Ø 42
$3 < L \leq 4$	Ø 45

BTFS 32

The minimum acceptable length of pipes is 0.5 metres plus one elbow.
The maximum acceptable length of pipes is 4 metres plus one elbow.
Maximum acceptable length must be reduced by one metre for each additional elbow installed.

Choosing the right diaphragm supplied with the boiler

Pipe length (m)	Diameter of the flue gas diaphragm (mm)
$0.5 \leq L \leq 1$	Ø 45
$1 < L \leq 2$	Ø 47
$2 < L \leq 3$	Ø 49
$3 < L \leq 4$	No diaphragm required

These pictures are merely an indication. For installation of optional fittings please refer to the instruction enclosed to the same fittings.

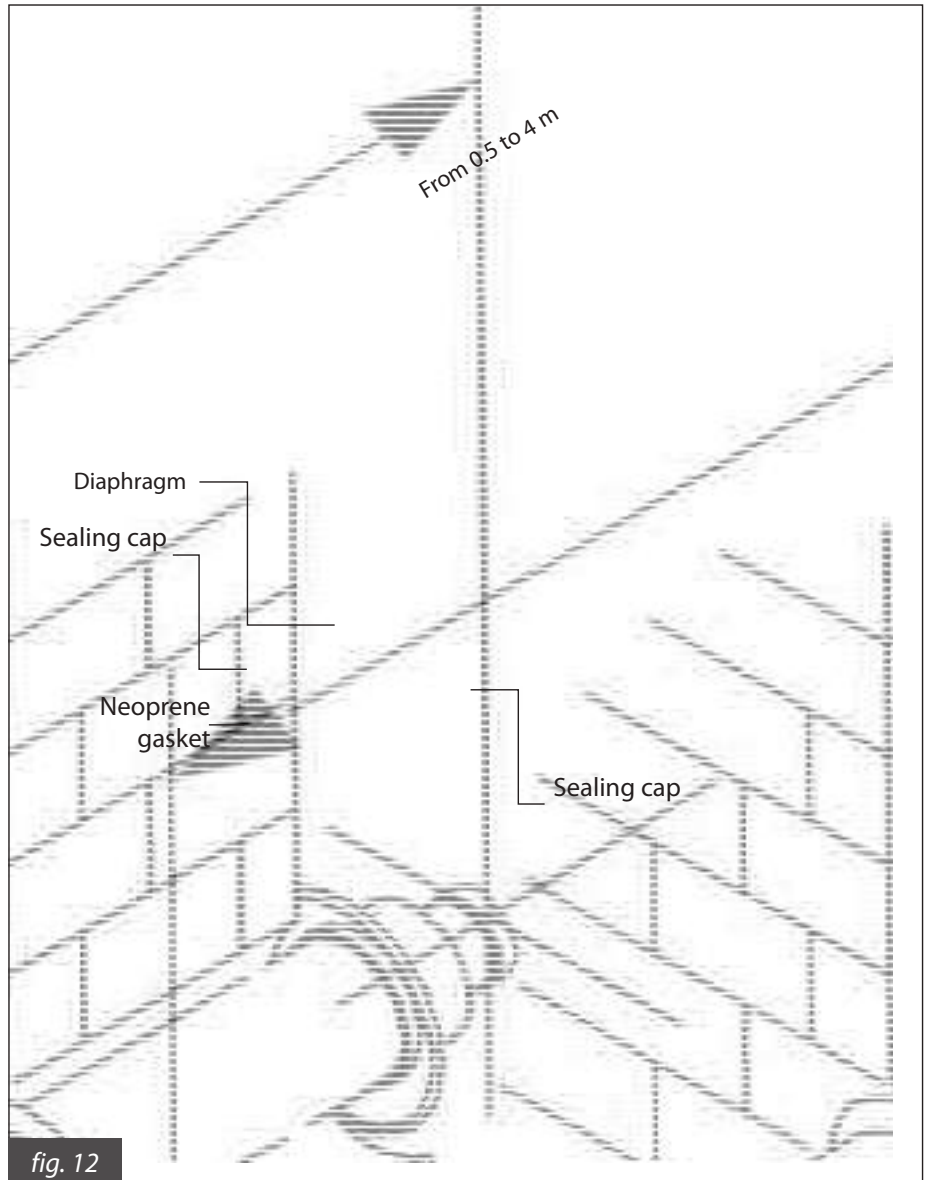

fig. 12

DIMENSIONS FOR CONNECTION TO A COAXIAL AIR/FLUE GAS SYSTEM

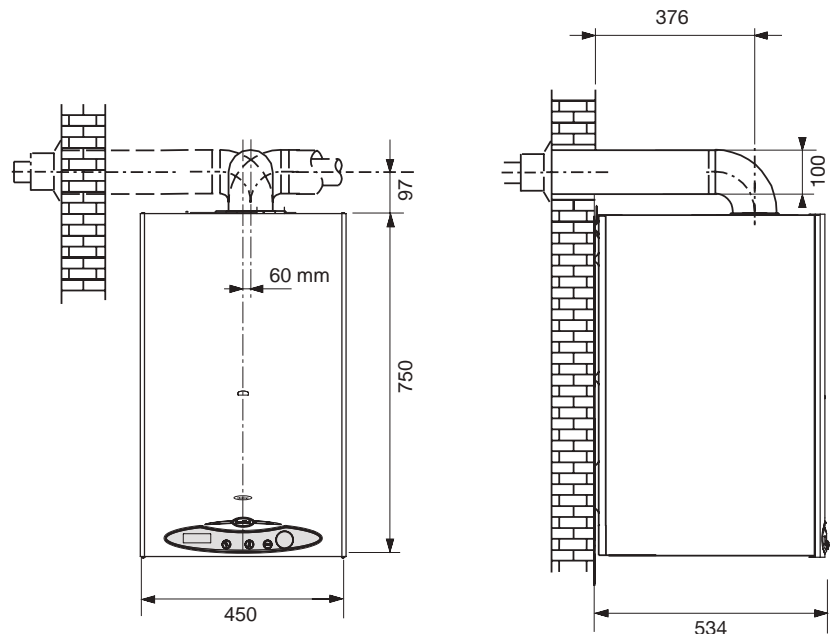



fig. 13

3.2.7.3. Air/flue gas system with 80 mm diameter split pipes

C12 - C32 - C42 - C52 - C82 installation types

When installing a split pipe air/flue gas system, use the OSDOPPIA06 standard split kit, which includes the following components (fig. 14):

- one Ø 80 mm flanged female pipe for connection to the flue gas discharge pipe
- one Ø 80 mm flanged female pipe for connection to the air intake pipe
- one standard air intake deflector
- one air intake terminal equipped with grille and anti-pulse device
- one Ø 51 mm air intake diaphragm to install in the air intake terminal according to the instructions given below
- fixing screws and sealing gaskets.

 **If the standard split pipe kit provided by the manufacturer is not installed, efficient operation can not be guaranteed.**

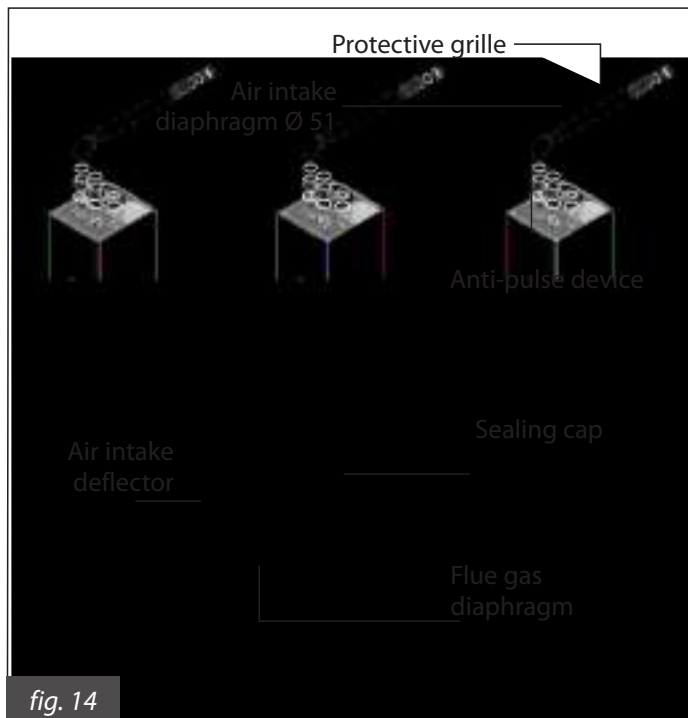

fig. 14

BTFS 24

The air intake pipe must be at least 1 metre long. Install the air intake anti-pulse terminal included in the standard split pipe kit, which contains a Ø 51 mm air intake diaphragm, and install the standard intake deflector.

Air intake

Each 90° wide radius (R=D) elbow in the air intake pipe is equivalent to 1 m linear length.
Each 90° narrow radius elbow in the air intake pipe is equivalent to 1.5 m linear length.
The load loss of the air intake terminal is not to be taken into account.

Flue gas discharge

Each 90° wide radius (R=D) elbow in the flue gas pipe is equivalent to 1.5 m linear length.
Each 90° narrow radius elbow in the flue gas pipe is equivalent to 3.5 m linear length.

Choosing the right diaphragm supplied with the boiler

Pipe length (m)	Diameter of the flue gas diaphragm (mm)
L < 2	Ø 45
2 < L < 17	Ø 49
17 < L < 33	-

BTFS 28

The air intake pipe must be at least 1 metre long. Install the air intake anti-pulse terminal included in the standard split pipe kit, which contains a Ø 51 mm air intake diaphragm, and install the standard intake deflector.

Air intake

Each 90° wide radius (R=D) elbow in the air intake pipe is equivalent to 1 m linear length.
Each 90° narrow radius elbow in the air intake pipe is equivalent to 1.5 m linear length.
The load loss of the air intake terminal is not to be taken into account.

Flue gas discharge

Each 90° wide radius (R=D) elbow in the flue gas pipe is equivalent to 2 m linear length.
Each 90° narrow radius elbow in the flue gas pipe is equivalent to 4 m linear length.

Choosing the right diaphragm supplied with the boiler

Pipe length (m)	Diameter of the flue gas diaphragm (mm)
1 ≤ L ≤ 11	Ø 49
11 < L ≤ 21	No diaphragm required

BTFS 32

The air intake pipe must be at least 1 metre long. Install the air intake anti-pulse terminal included in the standard split pipe kit and install the standard intake deflector.
Do NOT install the Ø 51 mm air intake diaphragm.

Air intake

Each 90° wide radius (R=D) elbow in the air intake pipe is equivalent to 1.5 m linear length.
Each 90° narrow radius elbow in the air intake pipe is equivalent to 2 m linear length.
The load loss of the air intake terminal is not to be taken into account.

Flue gas discharge

Each 90° wide radius (R=D) elbow in the flue gas pipe is equivalent to 2 m linear length.
Each 90° narrow radius elbow in the flue gas pipe is equivalent to 5 m linear length.

Choosing the right diaphragm supplied with the boiler

Pipe length (m)	Diameter of the flue gas diaphragm (mm)
1 ≤ L ≤ 10	Ø 49
10 < L ≤ 14	Ø 51
14 < L ≤ 22	No diaphragm required

These pictures are merely an indication. For installation of optional fittings please refer to the instruction enclosed to the same fittings.

3.2.7.4. Direct air intake and flue gas discharge with 80 mm diameter duct

B22 installation type

This type of installation requires the OSDOPPIA06 standard split pipe kit (fig. 14).

An 80 mm Ø female flanged pipe must be installed on the intake, and on top of it the intake terminal with the anti-pulse device, provided in the kit.

A standard air deflector (fig. 14) must also be installed.

Installation of the 51 mm air diaphragm depends on the boiler model, as described below.



If the manufacturer's standard split pipe kit is not used, correct operation of the boiler can not be guaranteed.

BTFS 24

Air intake

Fit onto the 80 mm Ø female flanged pipe the intake terminal and anti-pulse device provided in the kit, which includes the 51 mm air diaphragm. Then apply the standard air deflector (fig. 15).

Flue gas discharge

The minimum length of the flue gas discharge pipe is 0.5 metres.

Each 90° wide radius (R=D) elbow in the flue gas pipe is equivalent to 1.5 m linear length.

Each 90° narrow radius elbow in the flue gas pipe is equivalent to 3.5 m linear length.

Choosing the right diaphragm supplied with the boiler

Pipe length (m)	Diameter of the flue gas diaphragm (mm)
$0.5 \leq L \leq 8$	Ø 45
$8 < L \leq 14$	Ø 49
$14 < L \leq 19$	No diaphragm required

BTFS 28

Air intake

Fit onto the 80 mm Ø female flanged pipe the intake terminal and anti-pulse device provided in the kit, which includes the 51 mm air diaphragm. Then apply the standard air deflector (fig. 15).

Flue gas discharge

The minimum length of the flue gas discharge pipe is 0.5 metres.

Each 90° wide radius (R=D) elbow in the flue gas pipe is equivalent to 2 m linear length.

Each 90° narrow radius (R=D) elbow in the flue gas pipe is equivalent to 4 m linear length.

Choosing the right diaphragm supplied with the boiler

Pipe length (m)	Diameter of the flue gas diaphragm (mm)
$0.5 \leq L \leq 9.5$	Ø 49
$9.5 < L \leq 15.5$	No diaphragm required

BTFS 32

Air intake

Fit onto the 80 mm female flanged pipe the intake terminal and anti-pulse device provided in the kit. Then apply the standard air deflector (fig. 15).

Do NOT install the Ø 51 air intake diaphragm.

Flue gas discharge

The minimum length of the flue gas discharge pipe is 0.5 metres.

Each 90° wide radius (R=D) elbow in the flue gas pipe is equivalent to 2 m linear length.

Each 90° narrow radius (R=D) elbow in the flue gas pipe is equivalent to 5 m linear length.

Choosing the right diaphragm supplied with the boiler

Pipe length (m)	Diameter of the flue gas diaphragm (mm)
$0.5 \leq L \leq 5.5$	Ø 51
$5.5 < L \leq 10.5$	No diaphragm required

DIMENSIONS FOR CONNECTING THE FLUE GAS PIPE TO SEPARATE DUCTS

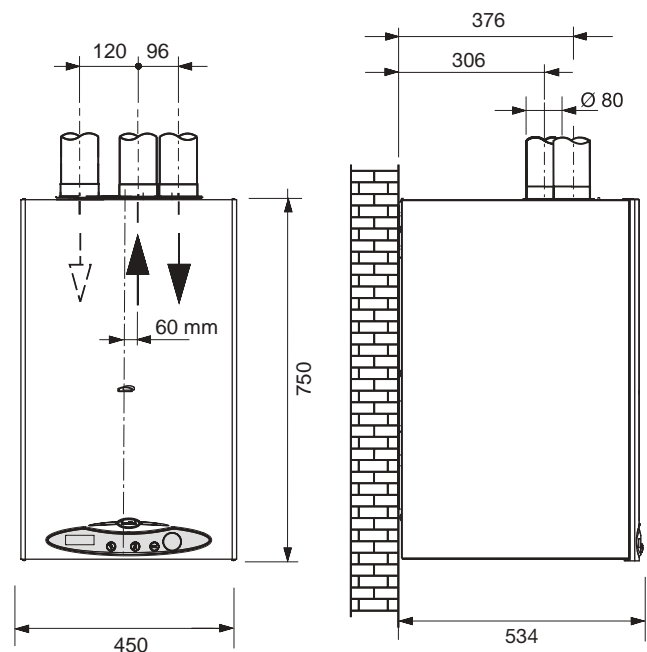

fig. 15

3.2.8. Measuring combustion efficiency

3.2.8.1. Chimney-sweep function

The boiler has a chimney-sweep function that can be used for testing boiler combustion efficiency and adjusting the burner.

To activate this function, it is necessary to open the front section of the casing for access to the controls. Proceed as follows:

- Unscrew two of the four screws securing the casing – either those on the left or those on the right (1, fig. 16).
- Open the casing without removing it (2, fig. 16).
- Remove the control panel mask by pulling the hooks on either side outwards and pulling the mask towards you (3, fig. 16).

The control panel is represented in fig. 17.

With selector 2 (fig. 1) on WINTER, the room thermostat (if there is one) set to **ON** and the boiler operating, press the **SPA** button (fig. 17) for at least 10 seconds. The boiler will switch off, perform the ignition sequence and then run at a set fixed rate, which corresponds to the **maxR** trimmer setting (fig. 17).

The chimney-sweep function lasts 15 minutes. To deactivate the function, turn selector 2 to a position other than WINTER.

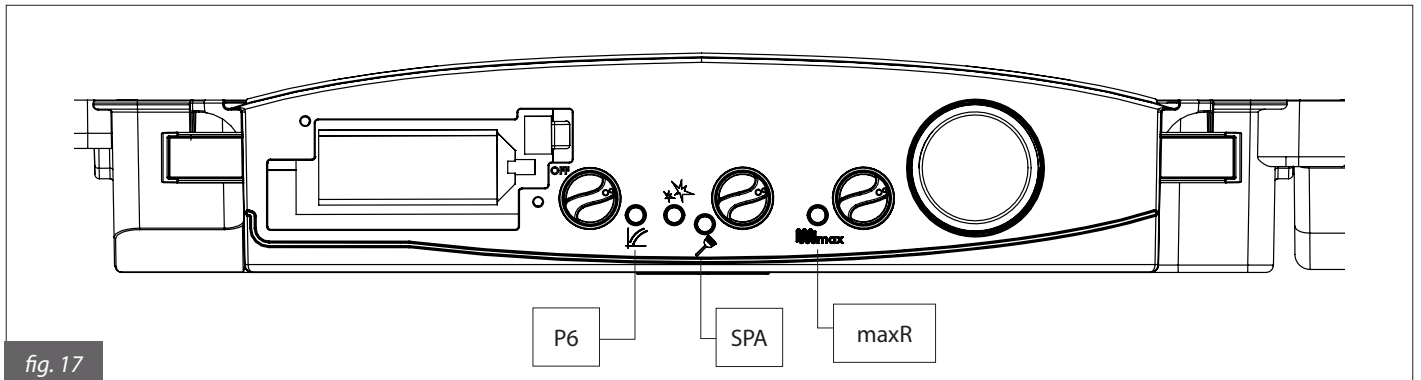
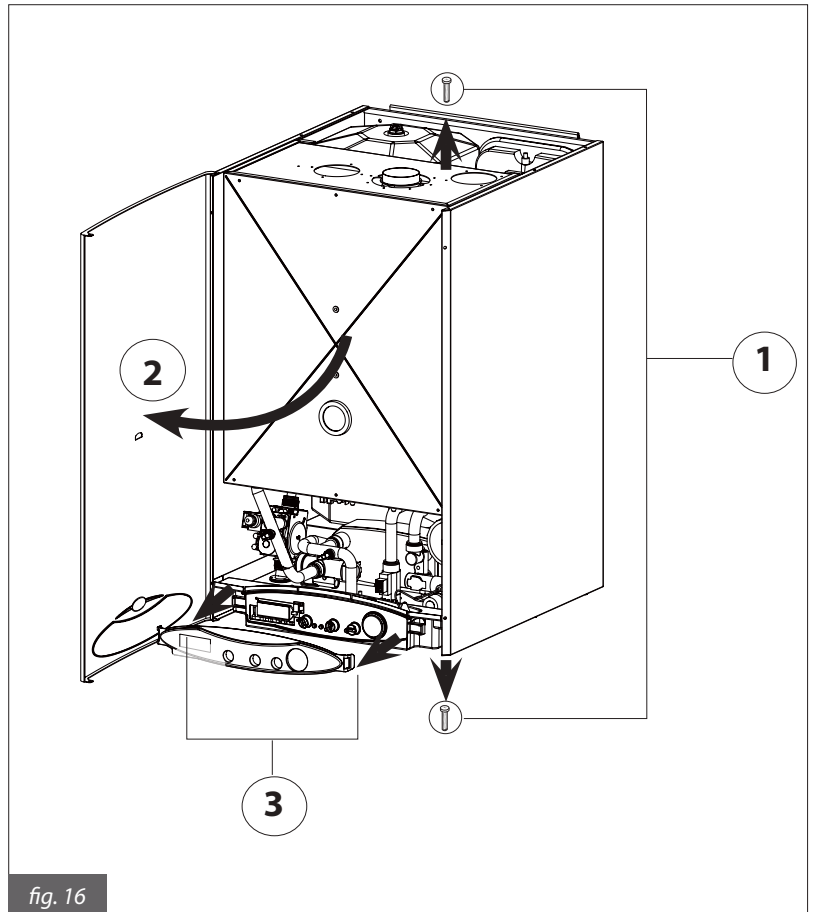

3.2.8.2. Measurement procedure

Coaxial pipe system

Proceed as follows to determine the combustion efficiency:

- measure the temperature of the combustion air through opening no. 1 (see fig. 18 A);
- measure the temperature of the flue gas and CO₂ concentration through opening no. 2 (see fig. 18 A).

N.B. This must be done when the boiler has reached the working temperature.

Split pipe system

Proceed as follows to determine the combustion efficiency:

- measure the combustion air through opening no. 2 (see fig. 18 B);
- measure the temperature of the flue gas and CO₂ concentration through opening no. 2 (see fig. 18 B).

N.B. This must be done when the boiler has reached the working temperature.

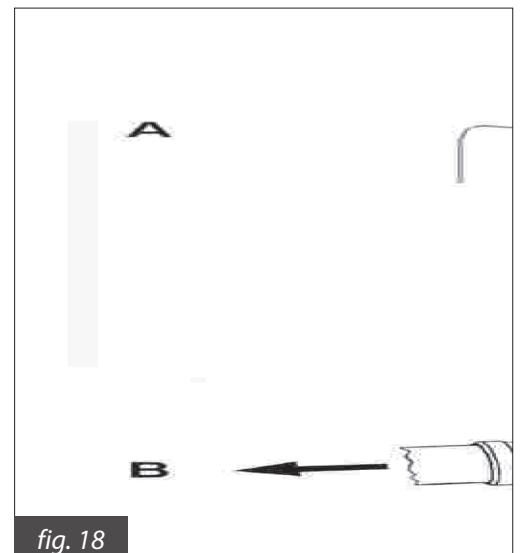

3.2.9. Gas mains connection

The cross-section of the gas supply pipe must be equal to or greater than that of the boiler gas inlet pipe. The cross-section of the pipe depends on its length and route and the gas flow rate. The gas pipe must be dimensioned accordingly.

Comply with the installation standards in force in the country of use, which are considered an integral part of this manual.



Before operating an internal gas distribution system and connecting it to the meter, it must be checked for leaks.

If any part of the system is going to be inaccessible, the leak test must be carried out before the pipes are covered.

The leak test must NOT be carried out using flammable gas: use air or nitrogen for this purpose.

If the pipes are already filled with gas, leak testing using a naked flame is forbidden. Use one of the specific products available on the market.



It is MANDATORY when connecting the boiler to the gas supply network to use a gasket of a suitable size and material (fig. 19).

Hemp, Teflon tape or the like must NOT be used with this type of fitting

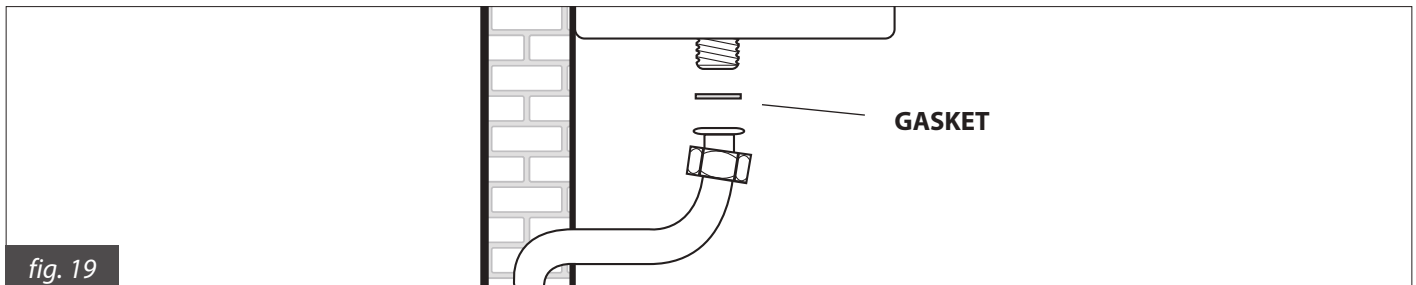

3.2.10. Plumbing connection

Before installing the boiler, it is advisable to clean the system to remove any impurities present in the components, which would damage the pump and the heat exchanger (see 3.2.4.).

CENTRAL HEATING SYSTEM

The CH flow and return pipes must be connected to the corresponding 3/4" M and R fittings on the boiler (figs. 6 and 7). When calculating the size of the CH pipes, bear in mind load losses caused by radiators, thermostatic valves, radiator gate valves and the overall configuration of the system.



It is advisable to convey the flow from the boiler safety valve to a sewer system. If this precaution is not taken, the boiler room may flood if the safety valve activates.

The manufacturer declines all liability for damage resulting from failure to comply with this technical precaution.

DOMESTIC HOT WATER SYSTEM

The water mains inlet pipe and the DHW flow pipe must be connected to the corresponding 1/2" F and C fittings on the boiler (figs. 6 and 7). The frequency at which the secondary plate heat exchanger needs to be cleaned depends on the hardness of the mains water.



If the water is very hard, it may be necessary to install a drinking water treatment device for domestic use in compliance with the applicable laws and standards in the country of use.

Water treatment is always advisable when the water hardness exceeds 20°F.

Due to the pH level, water treated using standard softeners may not be compatible with some of the components in the system.

3.2.11. Adjustable by-pass

The boiler is equipped with an adjustable by-pass that can be disabled by means of a screw.

Figure 20A shows the position of the screw to disable the by-pass.

Figure 20B shows the position of the screw to enable the by-pass.

The boiler is delivered with the by-pass disabled.

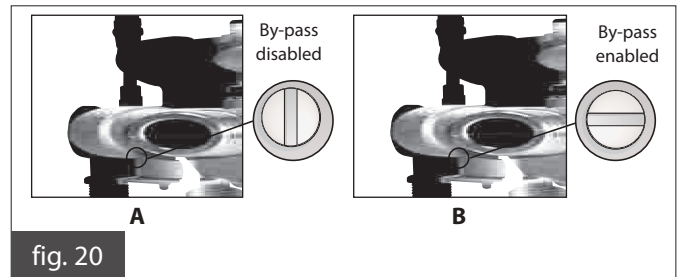

3.2.12. Power mains connection

The boiler is supplied with a three-pole power cable, already connected to the electronic board and protected by a cable clamp.

The boiler must be connected to a 230 V ~ 50 Hz mains supply.

When connecting the boiler to the power mains, keep to the phase/neutral system.

Installation must be carried out in compliance with the applicable standards, which are considered an integral part of this manual.

An easily accessible two-pole switch must be installed outside the boiler. The minimum distance between contacts must be 3 mm. The switch must allow the power supply to be switched off, so that maintenance and servicing can be performed in complete safety.

The power supply to the boiler must be fitted with a differential magnetothermal switch with an appropriate shutdown capacity.

The power supply must be adequately earthed.

This fundamental safety measure must be verified. If in doubt, ask a qualified electrician to check the system thoroughly.



The manufacturer declines all liability for damage resulting from failure to earth the system properly. Gas, water and CH pipes are not suitable for earthing a power network.

3.2.13. Room thermostat installation (optional)

The boiler can be connected to a room thermostat (optional).

The contacts must be properly sized in relation to a 5 mA 24 VDC load.

The wires must be connected to terminal M9 on the circuit board (fig. 23), after removing the jumper supplied standard with the boiler.

Room thermostat wires must NOT be grouped together with the power supply cables.

3.2.14. Installation of the OpenTherm remote control (optional)

The boiler can be connected to an OpenTherm remote control, an optional supplied by the manufacturer.

The remote control must be installed by a suitably qualified person.

For installation instructions, refer to the booklet accompanying the remote control.

Precautions to take when installing the remote control:

• **The remote control cables must NOT be routed together with power cables:** otherwise the disturbance would cause the remote control to malfunction.

- Position the remote control on a wall inside the building, about 1.5 metres from the floor, in a suitable position for measuring the environmental temperature.

- Do not install in alcoves, behind doors or curtains, near sources of heat, or exposed to sunlight, draughts or spray.



The remote control must not be connected to a 230 V ~ 50 Hz mains supply.

The remote control connection is protected against false polarity, which means the connections can be switched

Once the remote control has been installed, position the boiler selector (2 in fig. 1) in WINTER position.

The activation and deactivation of the heating and domestic hot water functions are operated directly by the remote control.

If the boiler selector is kept in a position other than WINTER, the correct functioning of the boiler and of the remote control are not guaranteed.



Boiler selector on WINTER

Refer to the booklet supplied with the remote control kit for programming instructions.



Only original remote controls supplied by the manufacturer must be used. If non-original remote controls are used, correct operation of the boiler cannot be guaranteed.

3.2.15. Installation of the (optional) external probe and sliding temperature operation

The boiler can be connected to an (optional) external temperature probe for sliding temperature operation.



**Only original external temperature probes supplied by the manufacturer must be used.
If non-original external temperature probes are used, correct operation of the boiler cannot be guaranteed.**

The external temperature probe must be connected by means of a double insulated wire, minimum cross-section 0.35 sq.mm. The probe must be connected to terminal M8 on the boiler's printed circuit board (fig. 23).

The temperature probe cables must NOT be routed together with power cables.

The temperature probe must be installed on an outside wall facing north or north-east, in a position protected from atmospheric agents. Do not install near a window, ventilation openings or sources of heat.

The external temperature probe automatically modifies the CH flow temperature in relation to:

- the outdoor temperature measured
- the thermoregulation curve selected
- the fictitious ambient temperature selected.

The thermoregulation curve is selected via trimmer **P6** (fig. 21).

For correct operation, it is important for trimmer P6 to be set to a value of 1-3 (figs. 21 and 22).

The fictitious ambient temperature is set via regulator regulator **4** (fig. 1), which loses its heating temperature control function (see subsection 1.4.7.) when the probe is installed.

Fig. 22 shows the curves for a fictitious temperature of 20°C.

When this value is increased or decreased via regulator **4**, the curves move up or down, respectively.

With a temperature setting of 20°C, for example, if you select the curve corresponding to parameter 1 and the outdoor temperature is -4°C, the CH flow temperature will be 50°C.

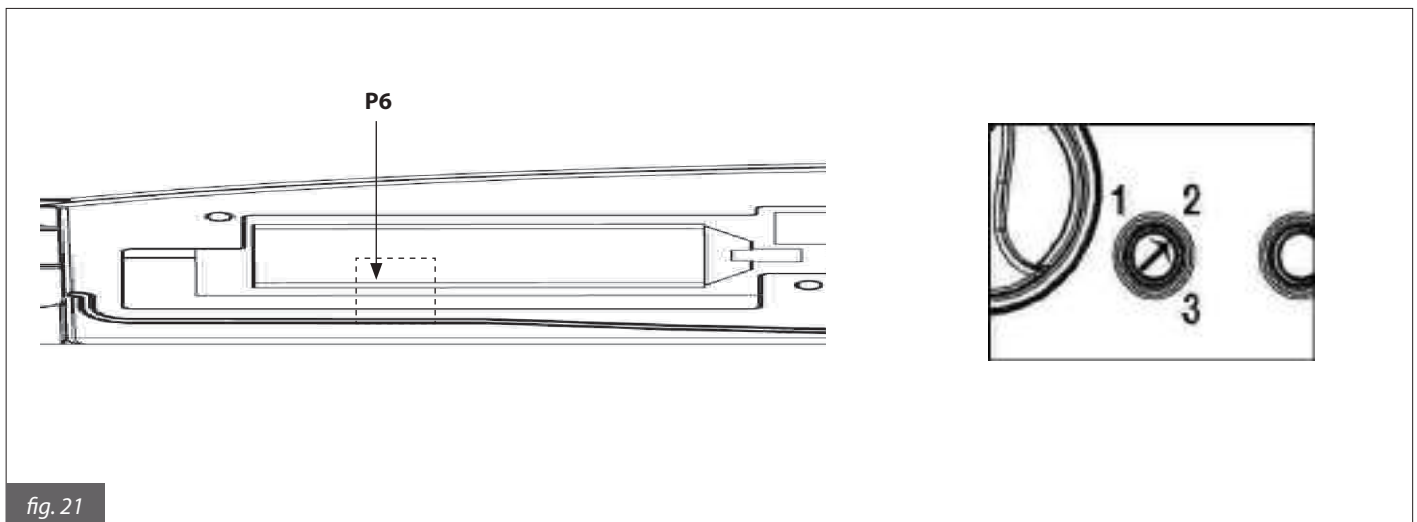

fig. 21

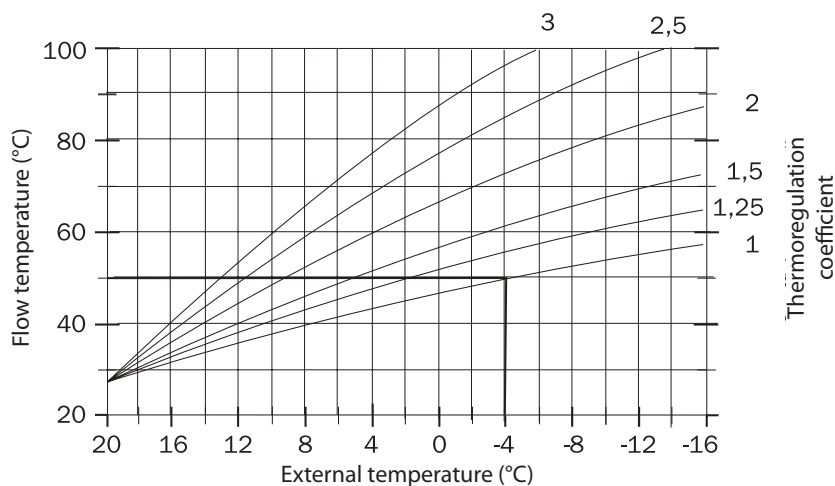

fig. 22

3.3. Filling the system

When all the boiler connections have been completed, the CH system can be filled with water.

This must be done with caution, following these steps in sequence.

- Open the air purging valve on all the radiators and check the efficiency of the automatic boiler valve.
- Gradually open the boiler filling tap and check that all the automatic air valves work efficiently.
- Close all the radiator valves as soon as water starts to come out.
- Check on the water pressure gauge that the reading is 1-1.3 bar.
- Close the filling tap and open all the valves on the radiators to remove any residual air.
- Start the boiler and as soon as the system reaches the working temperature, stop the pump and repeat the air bleeding procedure.
- Allow the system to cool down and the water pressure to return to 1-1.3 bar.

WARNING

As regards treating water in domestic heating systems, it is advisable to use specific products that are suitable for multi-metal plants, in order to optimize performance and safety, preserve these conditions over time, ensure regular operation of auxiliary equipment as well, and minimize energy consumption, in compliance with the applicable laws and standards.

WARNING

The low water pressure safety switch will prevent the burner from being started when the water pressure is below 0.4÷0.6 bar.

The water pressure in the CH system must not be below 1÷1.3 bar. Restore the correct value as needed and while the water in the system is cold.

The boiler pressure gauge shows the water pressure in the system.

WARNING

If the boiler is not used for a long time, the pump may not work.

BEFORE STARTING UP THE BOILER, PERFORM THE FOLLOWING PROCEDURE TO MAKE SURE THAT THE PUMP WORKS.

- **Unscrew the protection bolt in the centre front section of the pump motor.**
 - **Insert the tip of a screwdriver in the hole and rotate the circulation unit shaft clockwise.**
 - **Once the unblocking operation has been completed, screw the protection bolt back on and check for water leaks.**
- When the protection bolt is removed, some water may flow out. Before re-installing the external housing of the boiler, check that all internal surfaces are dry.**

3.4. Starting the boiler

3.4.1. Preliminary checks

Before starting the boiler, perform the following checks:

- The flue gas exhaust pipe and terminal must be installed as instructed. When the boiler is running, no combustion products must leak from any of the gaskets.
- Supply power to the boiler must be 230 V – 50 Hz.
- The system must be filled with water (pressure reading on water gauge 1÷1.3 bar).
- All the stopcocks on the pipes must be open.
- The gas supplied to the boiler must be of the type for which the boiler is designed. If necessary, convert the boiler following the instructions in subsection 3.6 - ADAPTATION TO OTHER GASES AND BURNER ADJUSTMENT. This operation must be carried out by a qualified service engineer.
- The gas supply stopcock must be open.
- There must be no gas leaks.
- The main power switch must be on.
- The boiler safety valve must not be blocked.
- There must be no water leaks.
- The pump must not be blocked.

The boiler is equipped with a three-speed circulation pump corresponding to three different residual heads. It is delivered with the circulation pump on the third speed setting.



If you wish to set a different speed, taking account of the water circulation requirements in the boiler (assured by the water pressure switch) and the resistance properties of the system, check operation of the boiler in all the conditions dictated by the features of the system (e.g. closure of one or more heating zones or of thermostat-controlled valves).

3.4.2. Switching on and off

To switch the boiler on and off, refer to the Instructions for the User, in section 1.

3.5. Wiring diagram

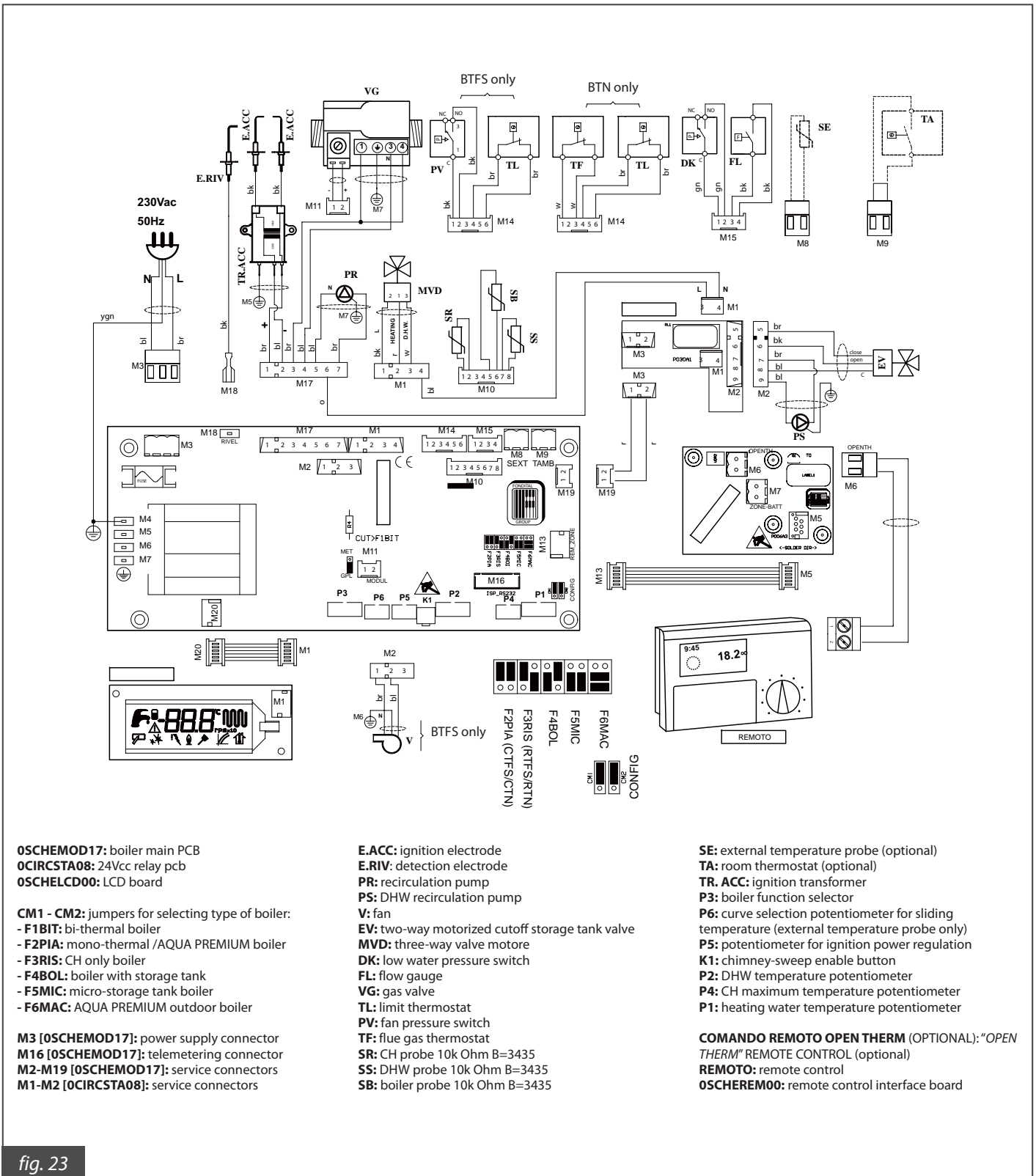

fig. 23

T (°C)	0	2	4	6	8
0	27203	24979	22959	21122	19451
10	17928	16539	15271	14113	13054
20	12084	11196	10382	9634	8948
30	8317	7736	7202	6709	6254
40	5835	5448	5090	4758	4452
50	4168	3904	3660	3433	3222
60	3026	2844	2674	2516	2369
70	2232	2104	1984	1872	1767
80	1670	1578	1492	1412	1336
90	1266	1199	1137	1079	1023

Table 12 - Relation between the temperature (°C) and nominal resistance (Ohm) of SR heating, SS hot water and SB storage tank probes.

3.6. Adapting to other gases and regulating the burner



This boiler is built to run on the type of gas specified on the order, which is shown on the packaging and on the boiler rating plate.

If you wish to switch to another type of gas, this must be done by a qualified technician using the accessories supplied by the manufacturer. He will make the necessary modifications and adjustments to ensure efficient operation of the boiler.

Switching from METHANE to LPG :

- Remove the main burner.
- Remove the nozzles of the main burner and replace them with ones of a diameter corresponding to the new type of gas (see Tables 3, 4, 5 and 6).
- IMPORTANT: Copper gaskets must be used.**
- Reinstall the main burner.
- On the PC board, switch the **MET- GPL** jumper to **GPL** (fig. 24).
- See points A, B and C below.

Switching from LPG to METHANE:

- Remove the main burner.
- Remove the nozzles of the main burner and replace them with ones of a diameter corresponding to the new type of gas (see Tables 3, 4, 5 and 6);
- IMPORTANT: Copper gaskets must be used.**
- Reinstall the main burner.
- On the PC board, switch the **MET- GPL** jumper to **MET** (fig. 24).
- See points A, B and C below.

A) Regulating maximum output

- Check the pressure of the gas supply (see Tables 3, 4, 5 and 6).
- Remove the plastic cap (**C**, fig. 25), on the modulating coil, which protects the pressure regulator adjusting screws.
- Connect a pressure gauge to point **V** (fig. 26).
- Position the **maxR** heat input regulator (fig. 27) on maximum (turn fully CLOCKWISE).
- Select WINTER on selector **2** (fig. 1).
- Start the boiler on chimney-sweep mode (see 3.2.8.1) and check whether the MAXIMUM pressure corresponds to the value in tables 3, 4, 5 and 6, depending on the model.
- Regulate the maximum burner pressure on nut **K** (external, fig. 28): turn CLOCKWISE to increase or ANTICLOCKWISE to decrease the pressure.
- In LPG-fired boilers, turn nut **K** fully CLOCKWISE.

B) Regulating minimum output

- Check the pressure gauge connected to point **V** (fig. 26).
- Disconnect the electrical wiring to the modulation coil (**M**, fig. 26).
- Ignite the burner and check whether the MAXIMUM pressure corresponds to the value in tables 3, 4, 5 and 6, depending on the model.
- Regulate the minimum pressure, holding nut **K** still with a 10mm spanner:

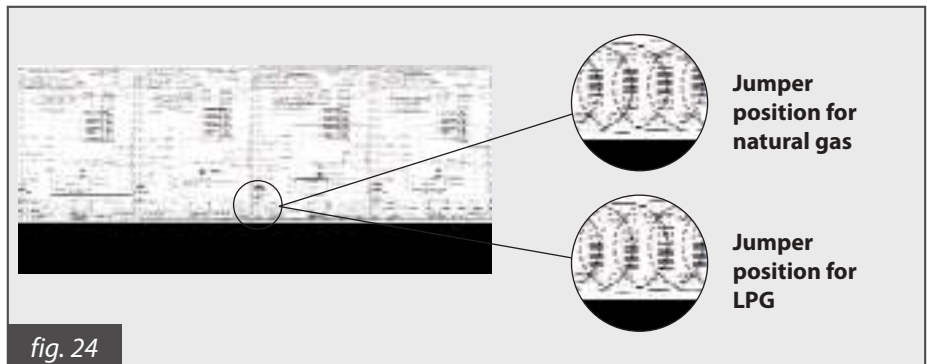

fig. 24

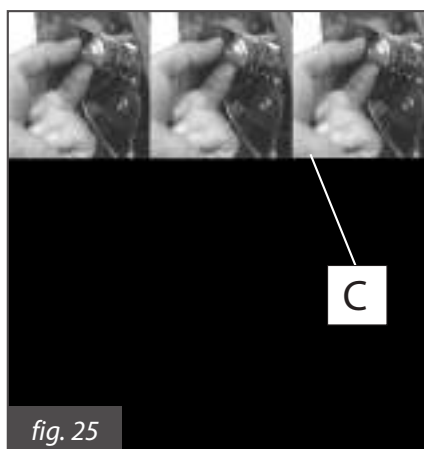

fig. 25

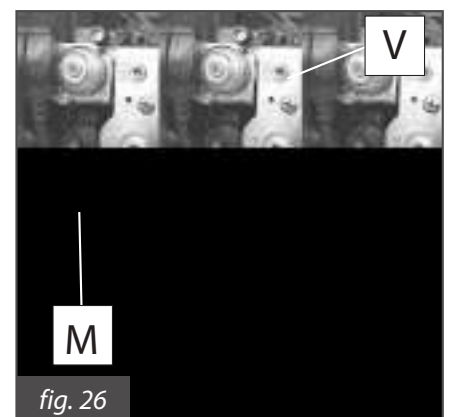

fig. 26

turn screw **W** CLOCKWISE to increase or ANTICLOCKWISE to decrease the pressure (fig. 28).

- Reconnect the electrical wiring to the modulation coil.

C) Final operations

- Return the **Pacc** trimmer (fig. 27) to the intermediate position and exit chimney-sweep mode (see 3.2.8.1.); check that burner ignition is correct and silent; if necessary, adjust the ignition power on the **Pacc** trimmer (clockwise to increase, anticlockwise to decrease).
- Recheck the min and max gas valve pressure values.
- Adjust finely as required (see A and B above).
- Fit on the plastic cap **C** (fig. 25).
- Close the gas pressure check points.
- **Check for gas leaks.**

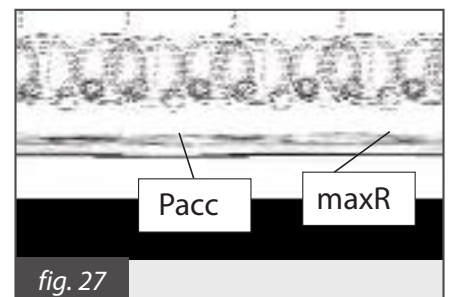

fig. 27

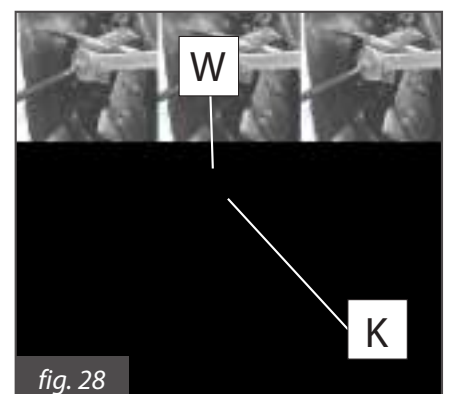

fig. 28

4. TESTING THE BOILER

4.1. Preliminary checks

Before testing the boiler, it is advisable to check that:

- the installation complies with the current regulations;
- the flue gas discharge pipe and terminal are installed as instructed: when the boiler is running, no combustion gas must leak from any of the gaskets;
- the power supply to the boiler is 230 V ~ 50 Hz;
- the system is full of water and the pressure reading is 1-1.3 bar;
- any system pipe stopcocks are open;
- the gas supplied to the boiler corresponds to the setting; if necessary, the boiler must be converted to the gas available (see section 3.6: Adapting to other gases);

- the gas cock is open;
- there are no gas leaks;
- the master switch is on;
- the boiler safety valve is not blocked;
- there are no water leaks.



If the boiler is not installed in accordance with the applicable laws and regulations, inform the system supervisor and do not test the boiler.

4.2. Switching on and off

Refer to the User Instructions for details of how to switch the boiler on and off.

5. MAINTENANCE

Maintenance and repairs must be carried out by a fully qualified technician.

The user is strongly advised to have the boiler serviced and repaired by one of the Manufacturer's fully qualified and authorised Service Centres

Correct maintenance of the boiler will allow it to work efficiently, without harming the environment, and in complete safety.



Before carrying out any maintenance work involving the replacement of components or internal cleaning of the boiler, disconnect the boiler from the mains.

5.1. Maintenance schedule

Routine maintenance must include a series of checks and cleaning operations.

Checks:

- General integrity of the boiler
- Boiler and gas supply leaks
- Boiler gas supply pressure
- Minimum and maximum gas pressure at the boiler nozzle
- Boiler ignition
- The integrity, state of preservation and seal of the flue gas discharge pipes
- State of the draught diverter device (BTN)
- Flue gas reflux in the room and discharge (BTN)
- Integrity of the safety thermostat on the draught diverter (BTN)
- Air pressure switch operation
- General integrity of the boiler safety devices
- Water leaks and oxidation of the boiler fittings
- Boiler safety valve efficiency
- Expansion vessel pressure
- Water pressure switch efficiency
- Integrity of the magnesium anode of the storage tank, and replacement if necessary.

Cleaning operations:

- Inside of the boiler
- Gas nozzles
- Air intake and flue gas discharge circuit (BTFS)
- Draft diverter (BTN)
- Boiler room ventilation grille (BTN)
- Flue gas side of the heat exchanger.

Checks to perform when using the boiler for the first time.





- User manual
- Suitability of the boiler room
- Boiler room ventilation openings (BTN)
- Flue gas discharge pipes – diameters and lengths
- Boiler installation in accordance with the instructions in this manual







If the boiler does not work properly or if it poses a danger to people, animals or property, inform the system supervisor and compile a report.

5.2. Combustion analysis

The boiler combustion parameter check to assess efficiency and polluting emissions must be performed in accordance with the applicable laws and regulations.

6. TROUBLESHOOTING

BOILER STATUS	PROBLEM	POSSIBLE CAUSE	SOLUTION
<p>The boiler has shut down. The symbol  is displayed and code E01 flashes.</p> <p>Turn selector 2 to RESET to resume boiler operation.</p>	Burner does not ignite.	Gas supply failure.	Check gas pressure. Check that the gas valve opens or whether any system safety valves have cut in.
		Gas valve disconnected.	Reconnect it.
		Gas valve faulty.	Replace it.
		PCB faulty.	Replace it.
	Burner does not ignite: spark not generated.	Spark electrode faulty.	Replace the spark electrode.
		Ignition transformer faulty.	Replace the ignition transformer.
		PCB faulty.	Replace PCB.
	Burner ignites for a few seconds and then goes off.	PCB does not detect flame: phase and neutral connections are inverted.	Verify correct neutral and phase connections to the power mains.
		Flame detection electrode wire faulty.	Reconnect or replace wire.
		Flame detection electrode faulty.	Replace electrode.
		PCB board does not detect flame.	Replace PCB.
		Ignition value setpoint too low.	Increase value setpoint.
Min. heat input not set correctly.		Check burner setting.	
<p>The boiler has shut down. The symbol  is displayed and code E20 flashes.</p> <p>Turn selector 2 to RESET to resume boiler operation.</p>	Flue gas pressure switch is not operating (model BTFS).	Flue gas pressure switch faulty.	Check flue gas pressure switch and replace, if necessary.
		Silicone pipes disconnected or damaged.	Reconnect or replace the silicone pipes.
		Insufficient air intake or flue gas discharge.	Check the air intake and flue gas pipes: unclog or replace as needed.
		Fan faulty.	Replace it.
		PCB faulty.	Replace it.
<p>The boiler has shut down. The symbol  is displayed and code E03 flashes.</p> <p>Turn selector 2 to RESET to resume boiler operation.</p>	Boiler safety thermostat has shut boiler down (models BTN).	Difficult draught at chimney.	Check the chimney and ambient air suction grilles.
		Flue gas thermostat faulty.	Replace it.
<p>The boiler has shut down. The symbol  is displayed and code E02 flashes.</p> <p>Turn selector 2 to RESET to resume boiler operation.</p>	Boiler safety thermostat has cut in.	CH water does not flow: pipes might be clogged, thermostatic valves might be shut, system stopcocks might be closed.	Check CH system.
		Pump blocked or faulty.	Check the pump.
<p>The boiler has shut down. The symbol  is displayed and code E02 flashes.</p> <p>Operation can be resumed by resetting the pressure in the system.</p>	Low water pressure in the system.	Possible water leaks.	Check system for leaks.
		Water pressure switch disconnected.	Reconnect it.
		Water pressure switch faulty.	Replace it

BOILER STATUS	PROBLEM	POSSIBLE CAUSE	SOLUTION
The boiler has shut down. The symbol  is displayed and code E05 flashes. Operation is resumed automatically when the cause of shutdown has been removed.	CH probe not working.	CH probe disconnected.	Reconnect it.
		CH probe faulty.	Replace it.
The boiler does not work in DHW mode. The symbol  is displayed and code E06 flashes. Operation is resumed automatically when the cause of shutdown has been removed.	DHW probe not working.	DHW probe disconnected.	Reconnect it.
		DHW probe faulty.	Replace it.
The boiler does not work in DHW mode. The symbol  is displayed and code E12 flashes. Operation is resumed automatically when the cause of shutdown has been removed.	Storage tank probe not working.	Storage tank probe disconnected.	Reconnect it.
		Storage tank probe faulty.	Replace it.
The boiler does not work in DHW mode.	DHW flow switch does not cut in.	System pressure or flow rate too low.	Check DHW system. Check flow meter filter.
		Flow meter sensors disconnected or faulty.	Replace or reconnect it.
		Flow meter stuck.	Replace it.
The boiler does not work properly. The symbol  is displayed and code E16 flashes. Operation is resumed automatically when the cause of shutdown has been removed.	Gas valve modulator not working.	Gas valve modulator disconnected.	Reconnect it.
		Gas valve modulator faulty.	Replace it.
The (optional) remote control is switched off. The symbol  is displayed and code E22 flashes. Operation is resumed automatically when the cause of shutdown has been removed.	No communication with remote control (optional, if connected previously).	Cable between boiler and remote control disconnected.	Reconnect it
		Remote control faulty.	Replace it.
The symbol  is displayed and code E23 flashes. Operation is resumed automatically when the cause of shutdown has been removed.	External probe (optional) not working (if connected previously).	External probe disconnected.	Reconnect it.
		External probe faulty.	Replace it.



OLIBMUEN22

fondital

Fondital S.p.A.

25079 VOBARNO (Brescia) Italy - Via Cerreto, 40

Tel. +39 0365/878.31 - Fax +39 0365/878.576

e mail: fondital@fondital.it - www.fondital.it

The manufacturer reserves the right to modify the products
as it deems necessary and useful, without affecting their basic features.